

Thermoelectric Cooling of LNA's to 200K

Glenn Jones and Sander Weinreb

Caltech, Pasadena, CA 91125

jones_gl@caltech.edu

1. Thermoelectric primer
2. HEMT noise model vs. temperature and frequency
3. Noise performance vs. cooler cost and reliability
4. Thermal packaging issues
5. Current results

Introduction to Thermoelectrics

- Thermoelectric coolers are solid-state heat pumps based on the Peltier effect. Because they are solid-state, they are extremely reliable.
- Current technology can only cool to about 170K, but further improvements are forecasted.
- With current technology, LNA performance can be significantly improved compared to room temperature at a fraction of the cost of traditional refrigerators.

TEC Operation

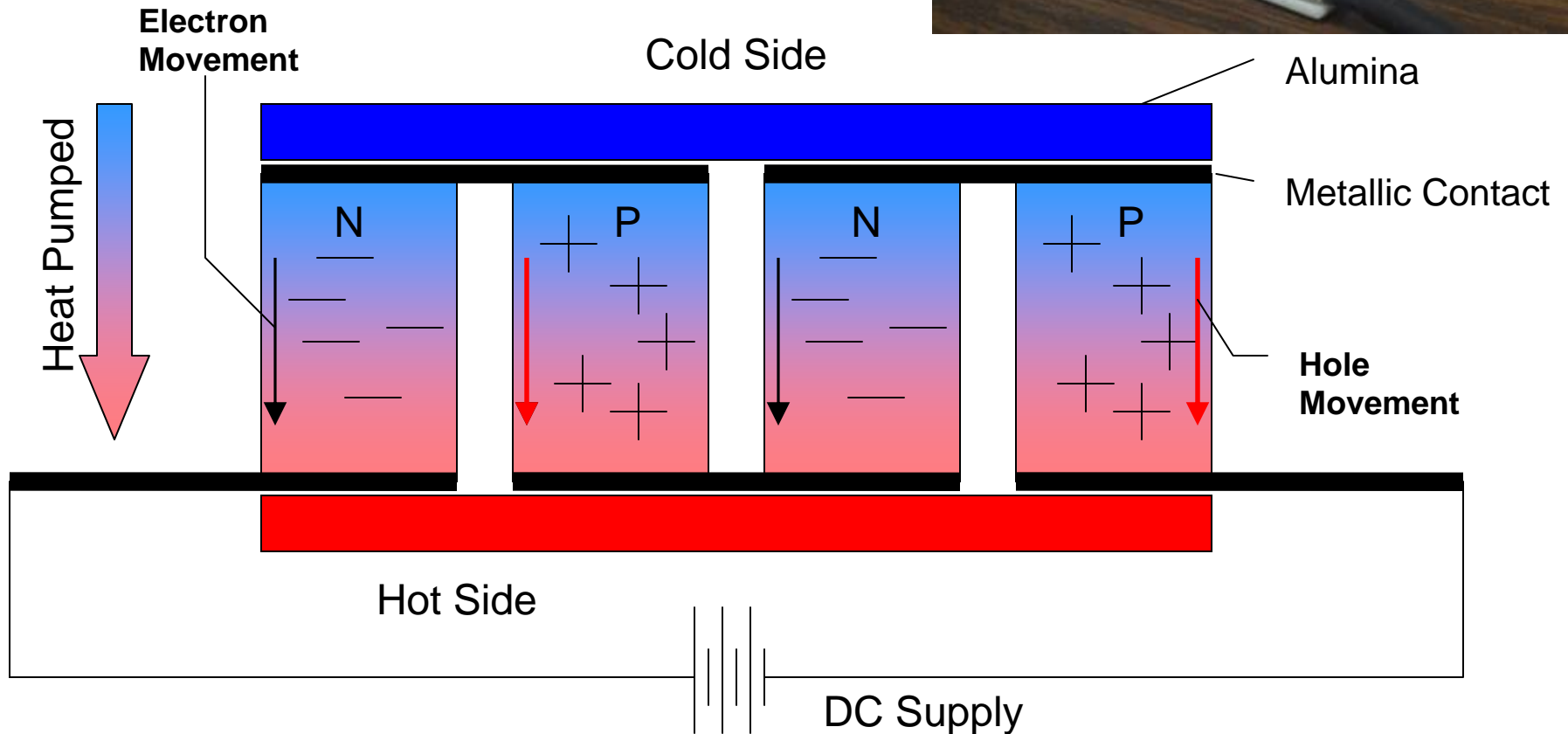
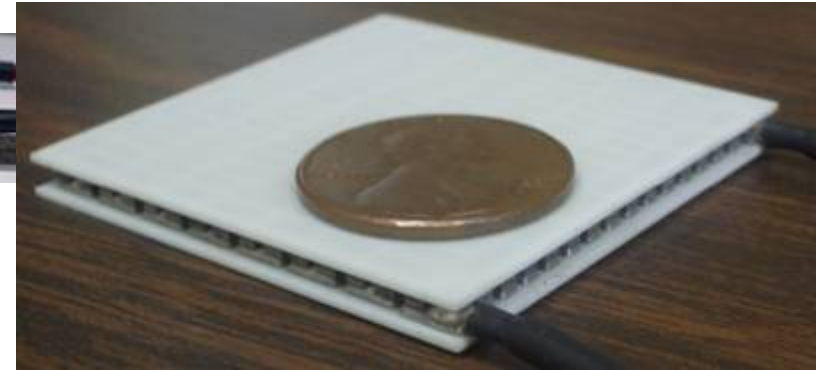

As they move from the lower energy level in the P-type material to the higher energy level in the N-type, the electrons absorb heat from the cold side. At the hot side, the opposite effect occurs: electrons release thermal energy as they move from the high energy N-type to the low energy P-type material.

Typical Thermoelectric Coolers

MELCOR Thermoelectrics 5-Stage Cooler 5CP 040 065-127-71-31-17-7 L

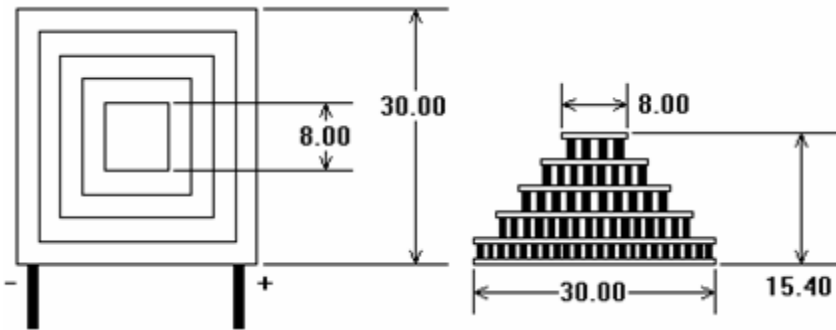

Dimensions in mm

Heat Pumped at Cold Side (Q_c)

$T_{hot}=301.8\text{ K}$, Current = 1.70 Amps, Voltage = 14.60 Volts

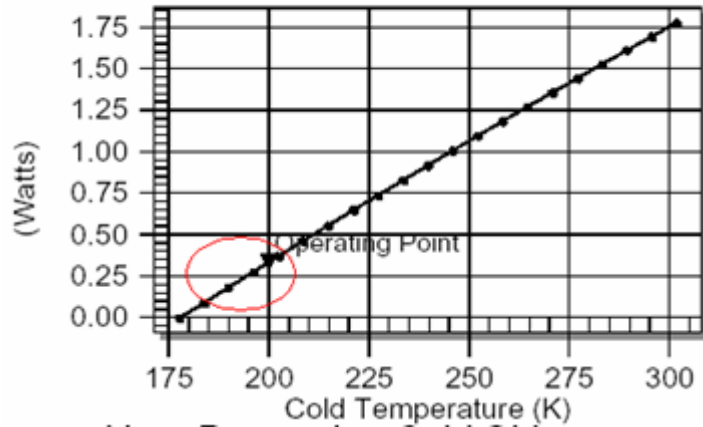

Ref: Datasheet at <http://www.melcor.com/>

Marlow Industries 4-Stage Cooler SP2394

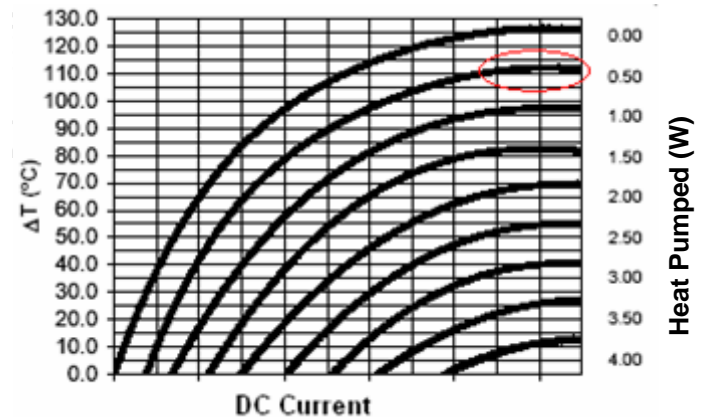
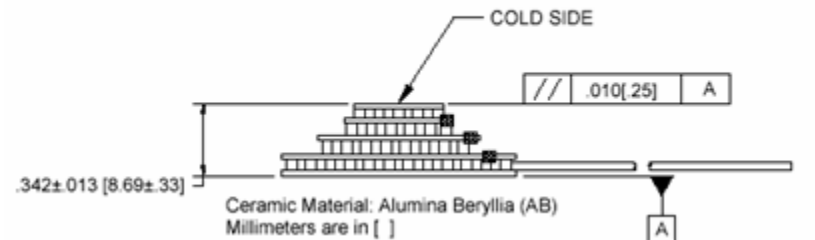
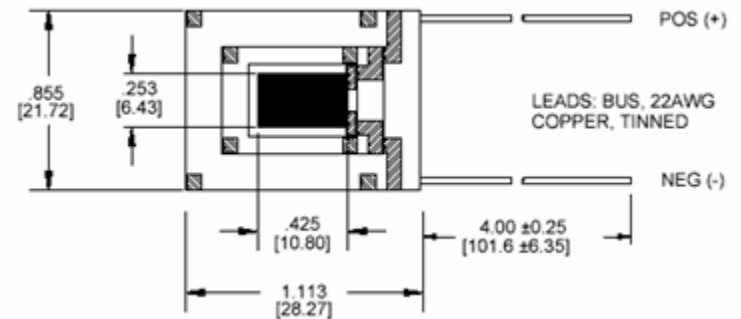

Ref: Datasheet at <http://www.marlow.com/>

Noise Model for InP HEMT

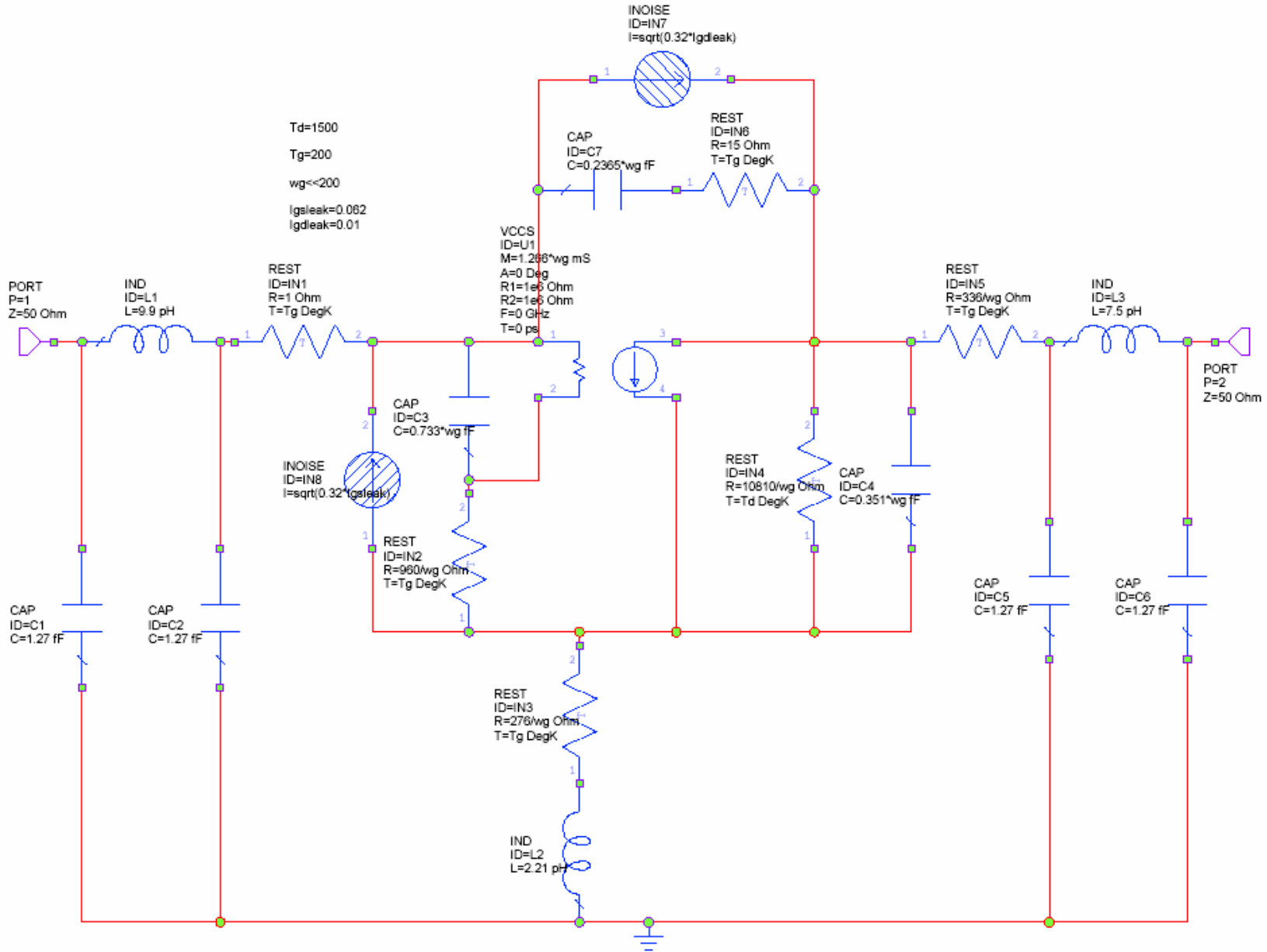

Noise Model for InP HEMT

Noise
rel

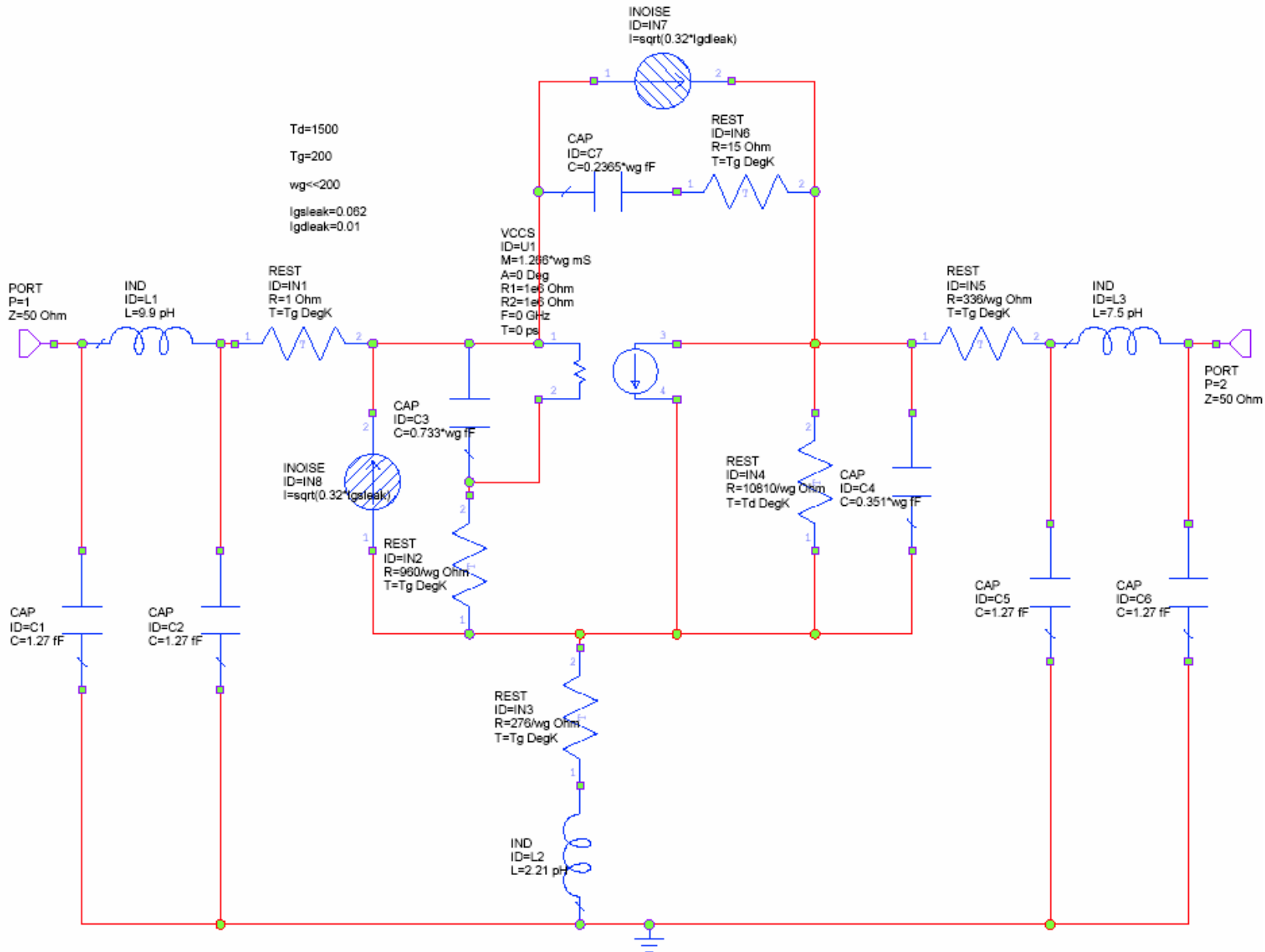

Noise Model for InP HEMT

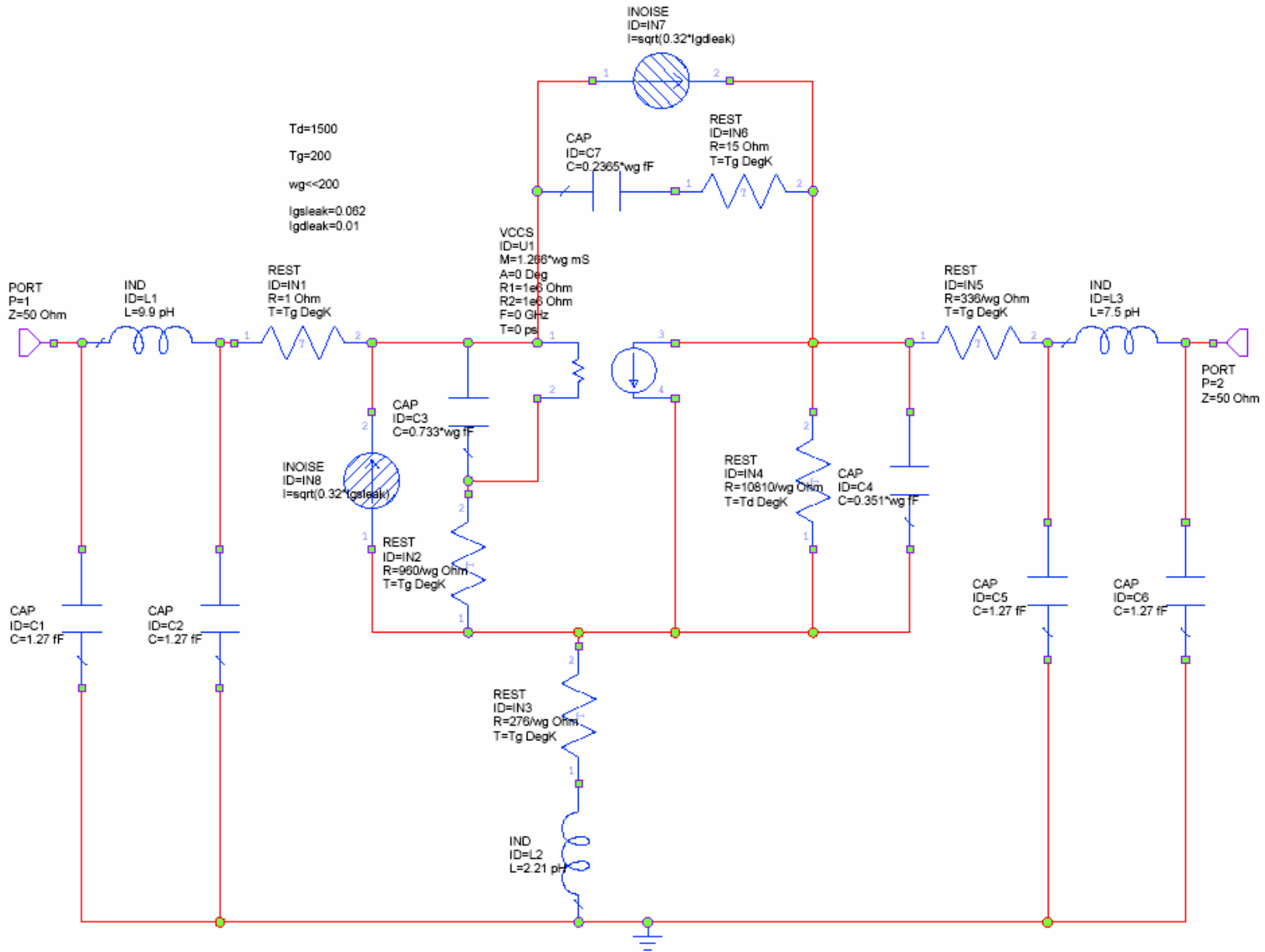

Noise Model for InP HEMT

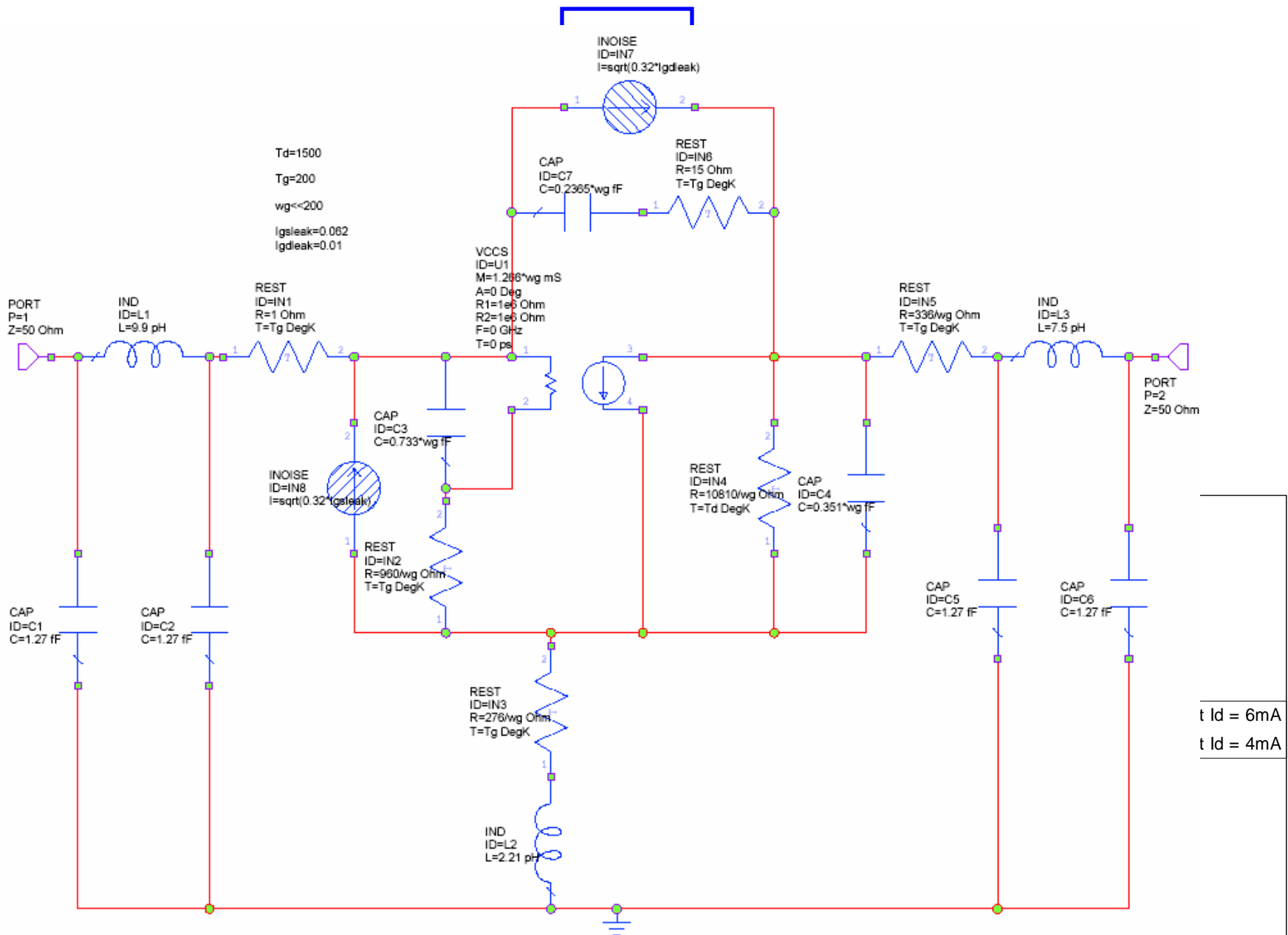

Simulation Results: 80um InP HEMT from NGST

At 1.4 GHz

Tphys(K)	Td (K)	Id (mA)	Igsleak (nA)	Igdleak (nA)	Tmin (K)
300	2100	8	352	100	7.12
250	1800	6	133	30	4.86
200	1500	6	104	10	3.83
130	1080	4	53	4	2.45
12	372	2	25	4	0.49

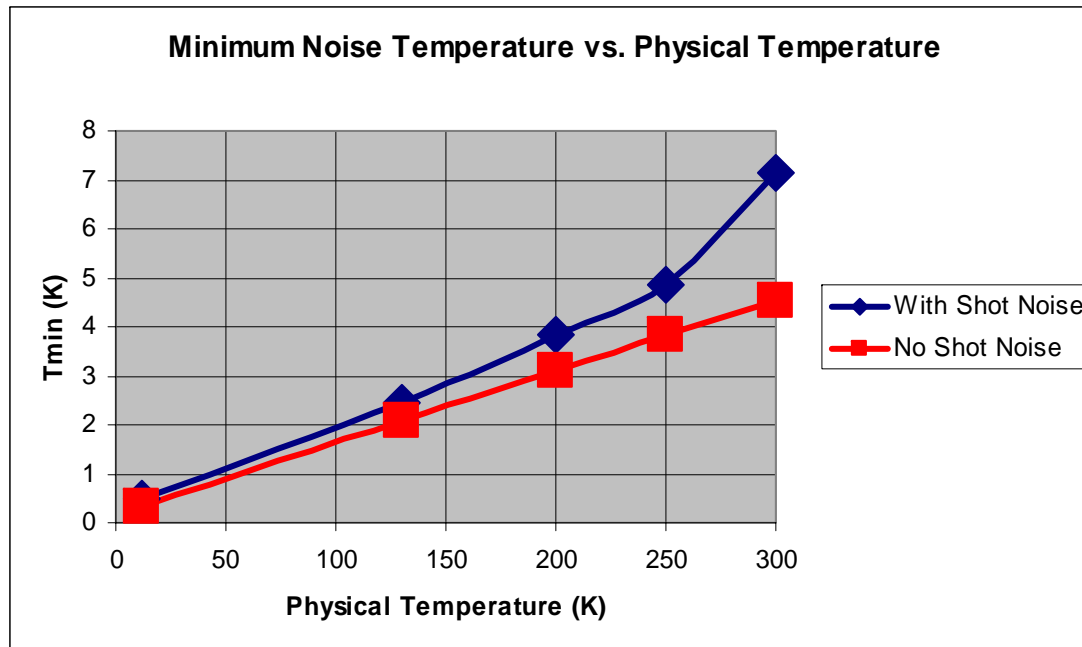

Thermoelectric cooling provides ~25% improvement in sensitivity at low cost

Temp	Typical Cooler	Typical System Noise @1.4GHz	Typical System Noise @8.4GHz	Typical System Noise @32GHz	Cost \$K	Life Hrs
300	None	24K	45K	125K		-
200	Thermoelectric	20K	37K	97K	0.5	>200,000
77	Sunpower Cryotel	16K	24K	46K	10	50,000
30	Sunpower Cryotel LT	15K	31K	39K	10	50,000
12	CTI 350 Gifford-McMann	14K	19K	35K	12	10,000
Typical Antenna + Sky Noise		12K	15K	25K		

For a \$1 million antenna, a \$10K cooling budget is acceptable, but for an array of 100-1000 antennas, the low cost and high reliability of thermoelectric coolers can offer huge savings.

Prototype Dewar for Thermoelectric Tests

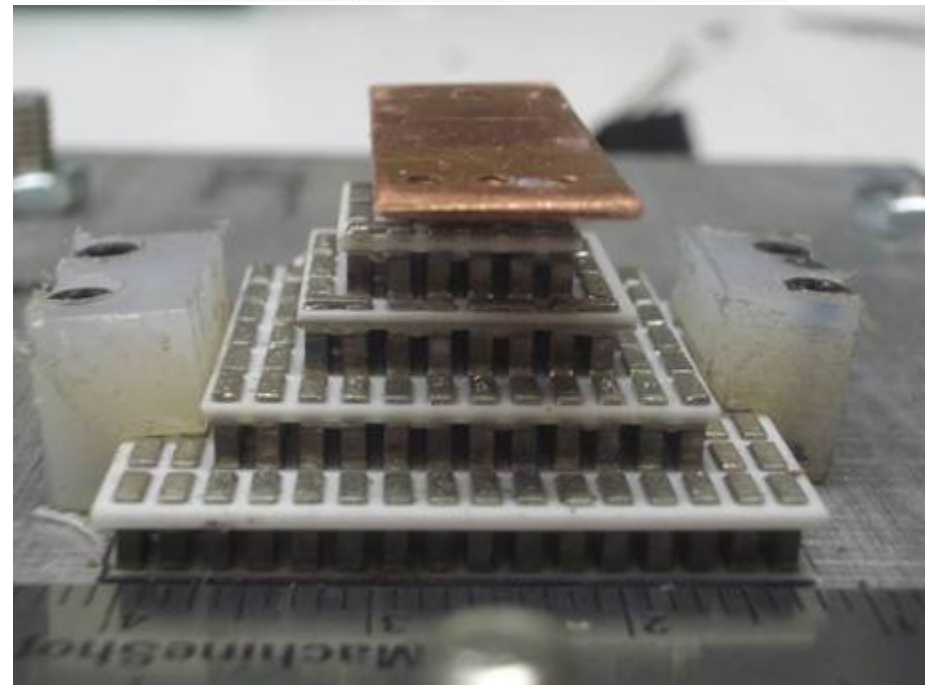
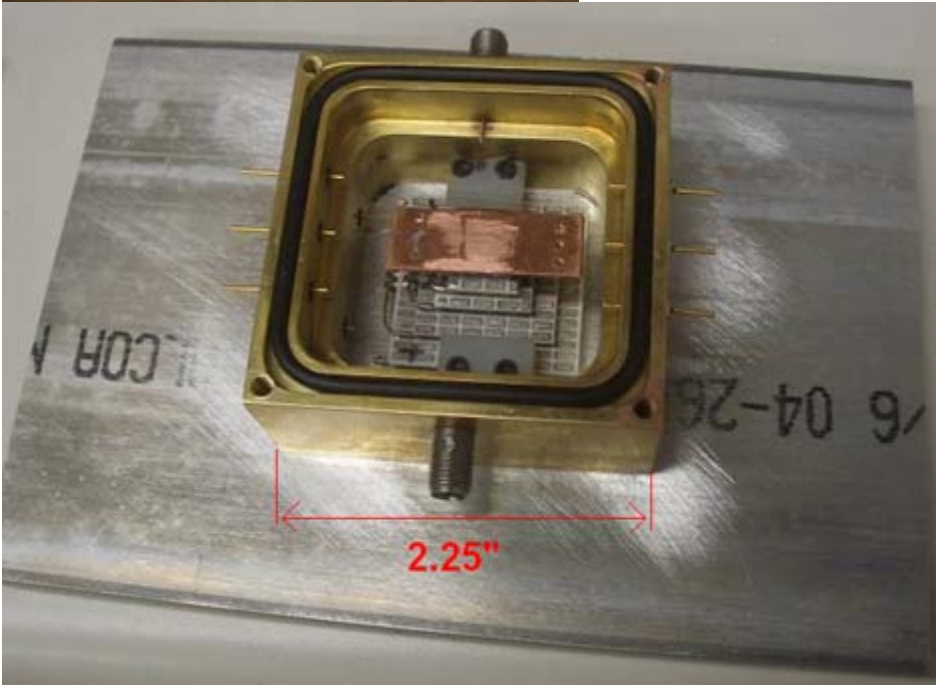
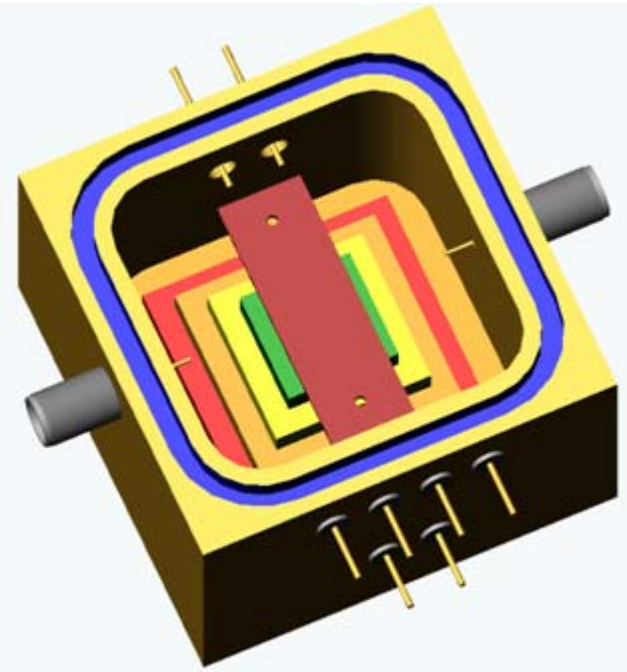

TEC Test Results and Thermal Considerations

- Best performance is achieved in a vacuum where radiation is the dominant heat transfer mechanism. At 20 millitorr, the 5-stage TEC attains 195K in the test Dewar with a 50mW active heat load.
- Without a vacuum, the largest heat load is due to convection, especially within the layers of the thermoelectric cooler.
- Insulation helps reduce convection around the TEC. Temperatures down to 230K are easily achieved with modest foam insulation in the test Dewar at atmospheric pressure. These temperatures should be achievable even with only 3 or 4 stages of TE cooling.
- Other options to consider: Mylar or perlite super-insulation, welded vacuum enclosures...

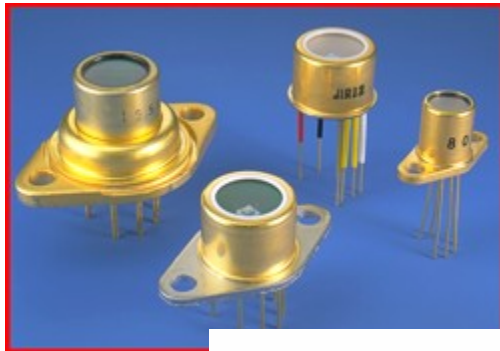

4 Stage TEC cooled IR detector operates at 200K
 Ref: <http://www.judsontechnologies.com/>

