

LO PHASE REFERENCE DISTRIBUTION BY COMMUNICATION SATELLITE

J. Bardin, S. Weinreb, D. Bagri
Jet Propulsion Laboratory,
California Institute of Technology
01/08/2005





An LO Phase Link Using a Commercial Geostationary Satellite



- Motivation
- Two Way Time Transfer
- System Design
- Hardware
- Experimental Results
- Conclusions



LO DISTRIBUTION METHODS



- Hydrogen Masers
 - Extremely Costly
 - Exhibit significant drift over time scales on the order of days
- Fiber Optic Links
 - Requires buried fibers
 - Difficult to impliment over more than 100km
 - Round trip correction system required



ALTERNATIVE LO DISTRIBUTION APPROACH



- Two Way Satellite Time Transfer
 - Commercial satellites available
 - Significant cost reduction when compared to Hydrogen Masers
 - Large footprint- entire US (including Hawaii) with just one satellite.

Goals of current work:

- Determine feasibility of achieving 1ps level time transfer using a satellite link.
- Make use of inexpensive Ku band transmit/receive equipment.



TWO WAY TIME TRANSFER

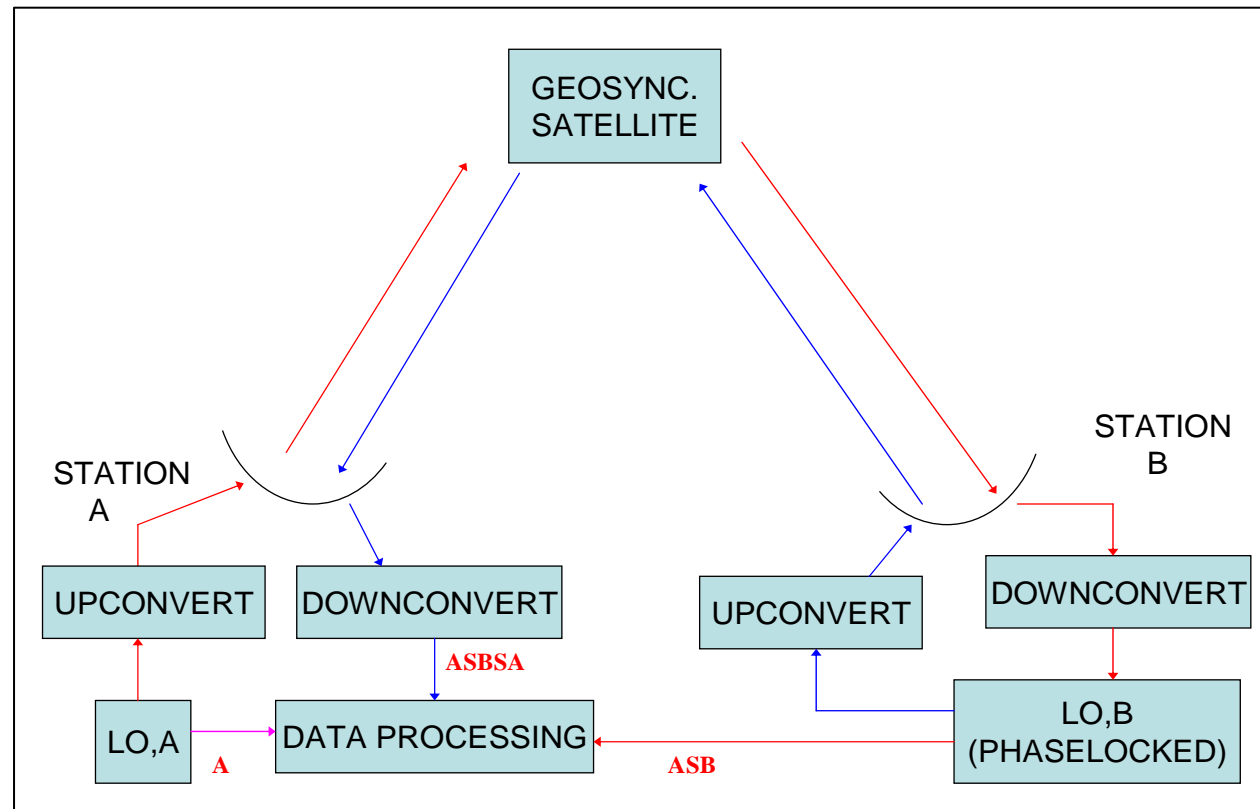

$$\phi_{RESIDUAL} = \phi_{ONE-WAY} - \frac{\phi_{ROUND-TRIP}}{2}$$



MODULATION SCHEME

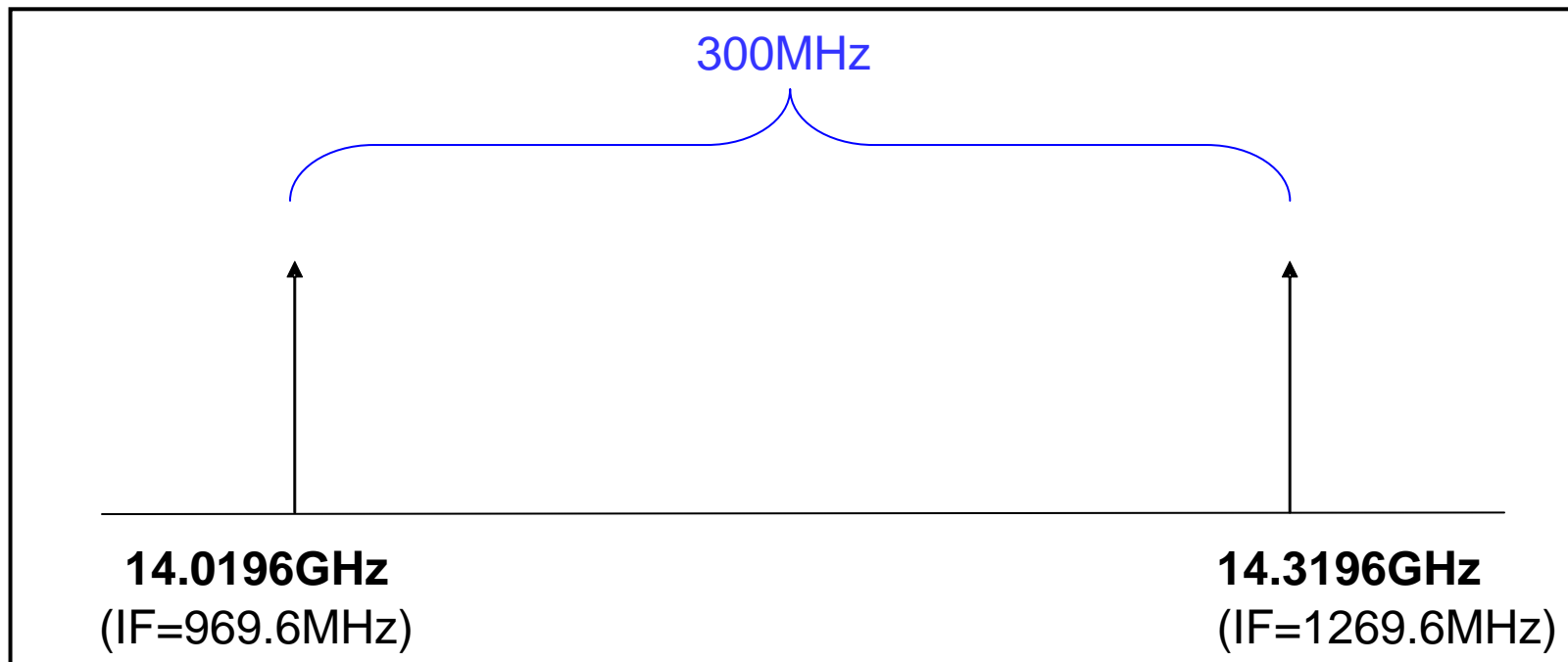



INTRINSIC LIMITATIONS



-
- Signal to noise ratio
 - SNR sets an upper limit on achievable performance

 - Ionospheric Dispersion
 - Frequency dependent effect related to the total electron content in the ionosphere. Violates assumption of path reciprocity. Important effect which can be corrected for by either ASA and BSB measurements or ionospheric modeling.



BLOCK DIAGRAM

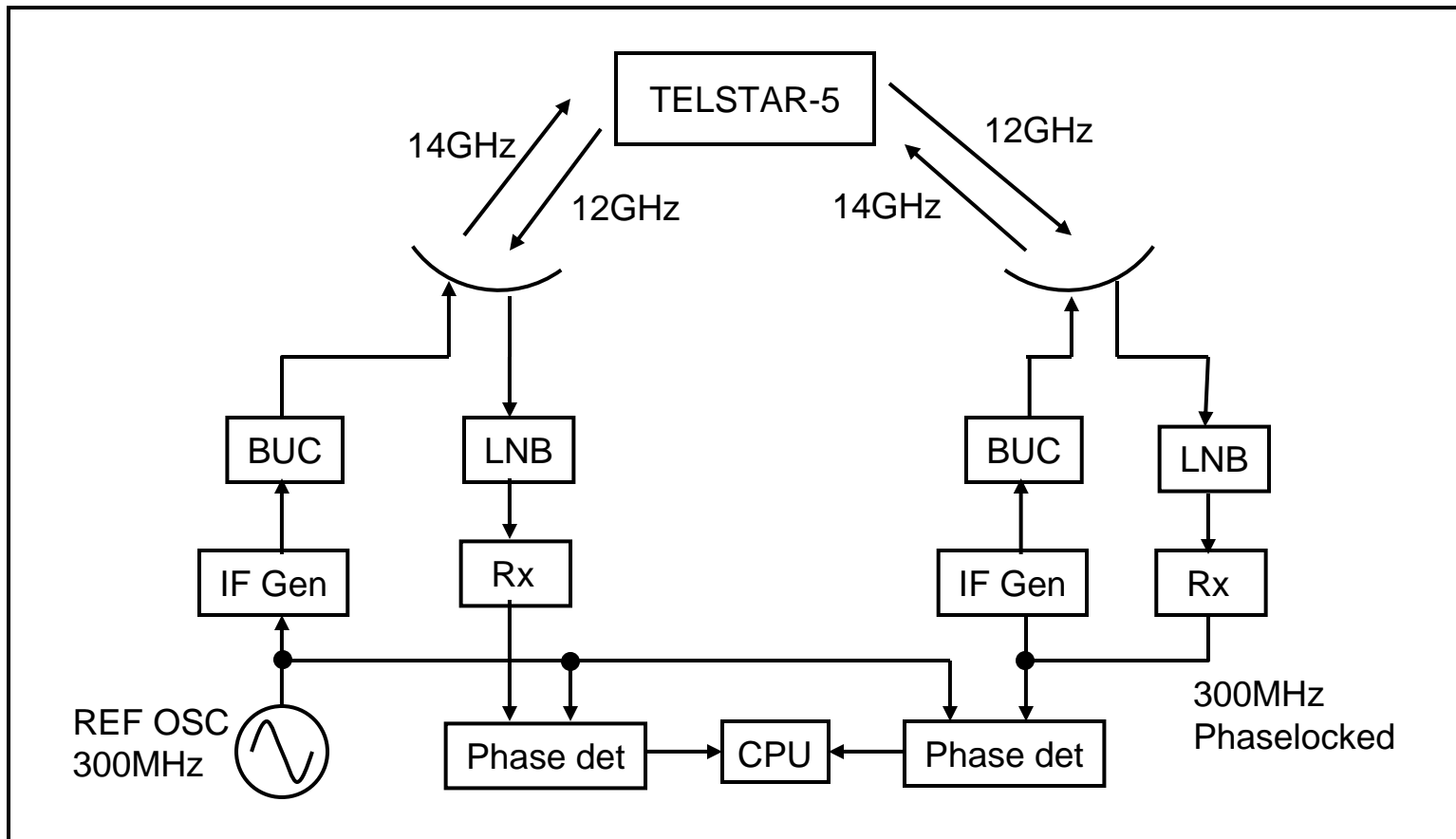



TELSTAR-5



- Telstar 5 is a commercial communications satellite with four 54MHz-wide and 24 27MHz-wide 100W transponders in the 12/14GHz band.
- Caltech leased three 100kHz bands in transponders 1 and 17 for \$1600/month.

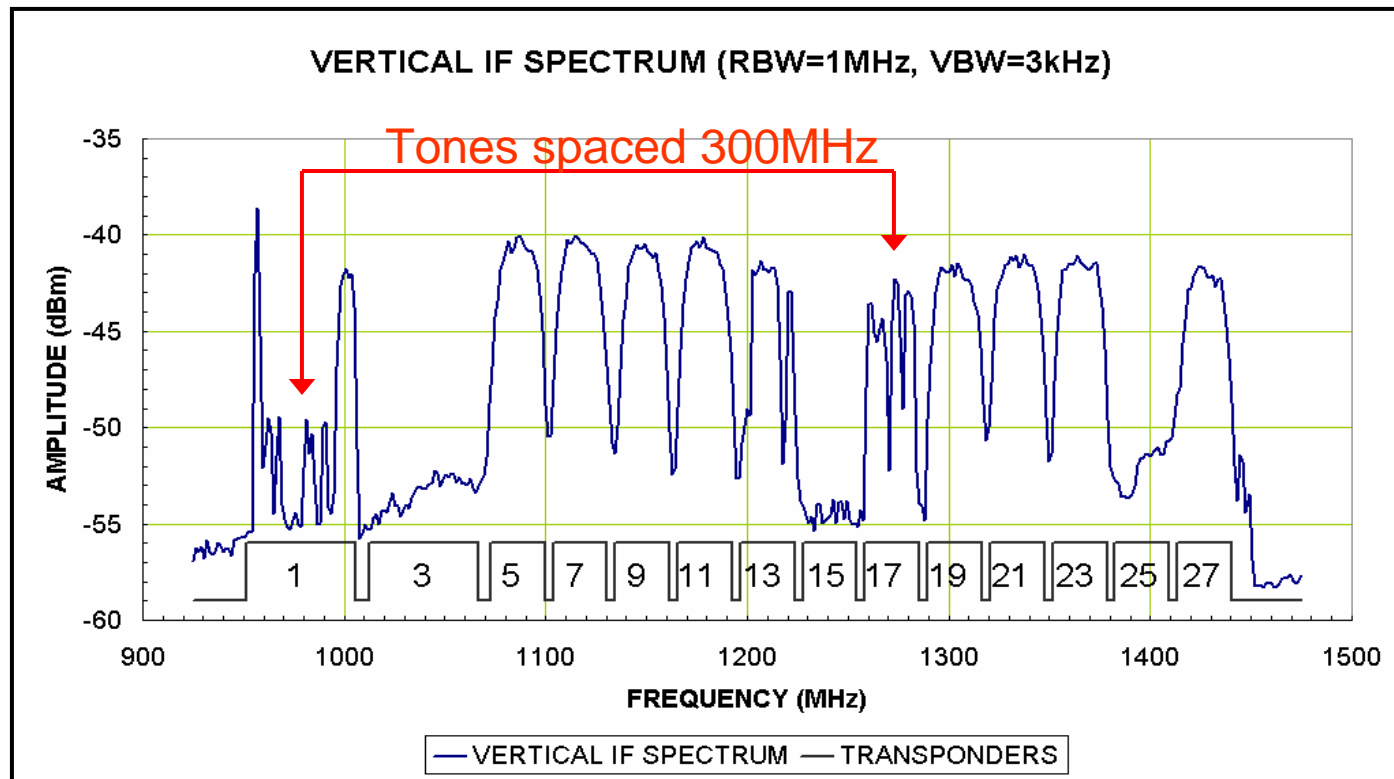



ANTENNAS





TAMPA MICROWAVE BUC



OUTPUT POWER: 1W



NEW JAPAN RADIO PHASELOCKED LNB

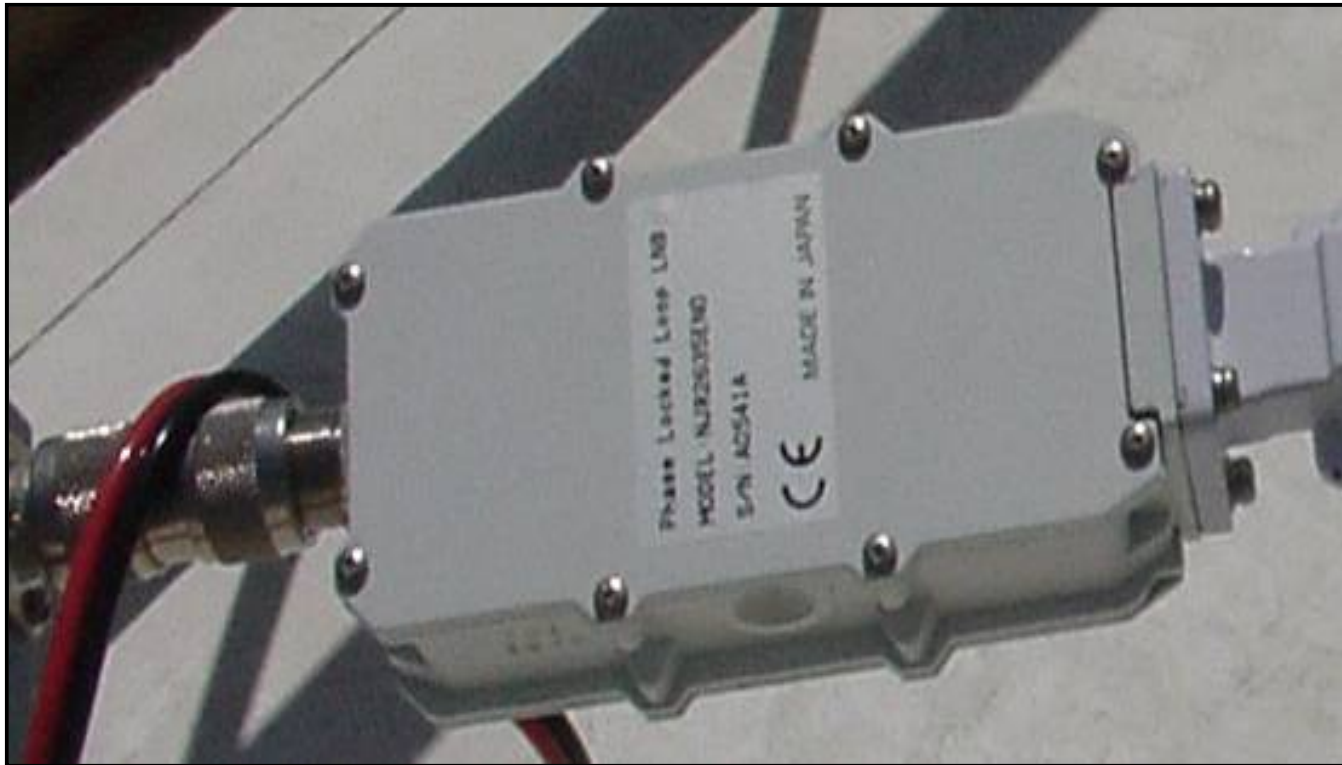

NF = 0.9dB (66.8K), Gain = 55dB



STATION A HARDWARE

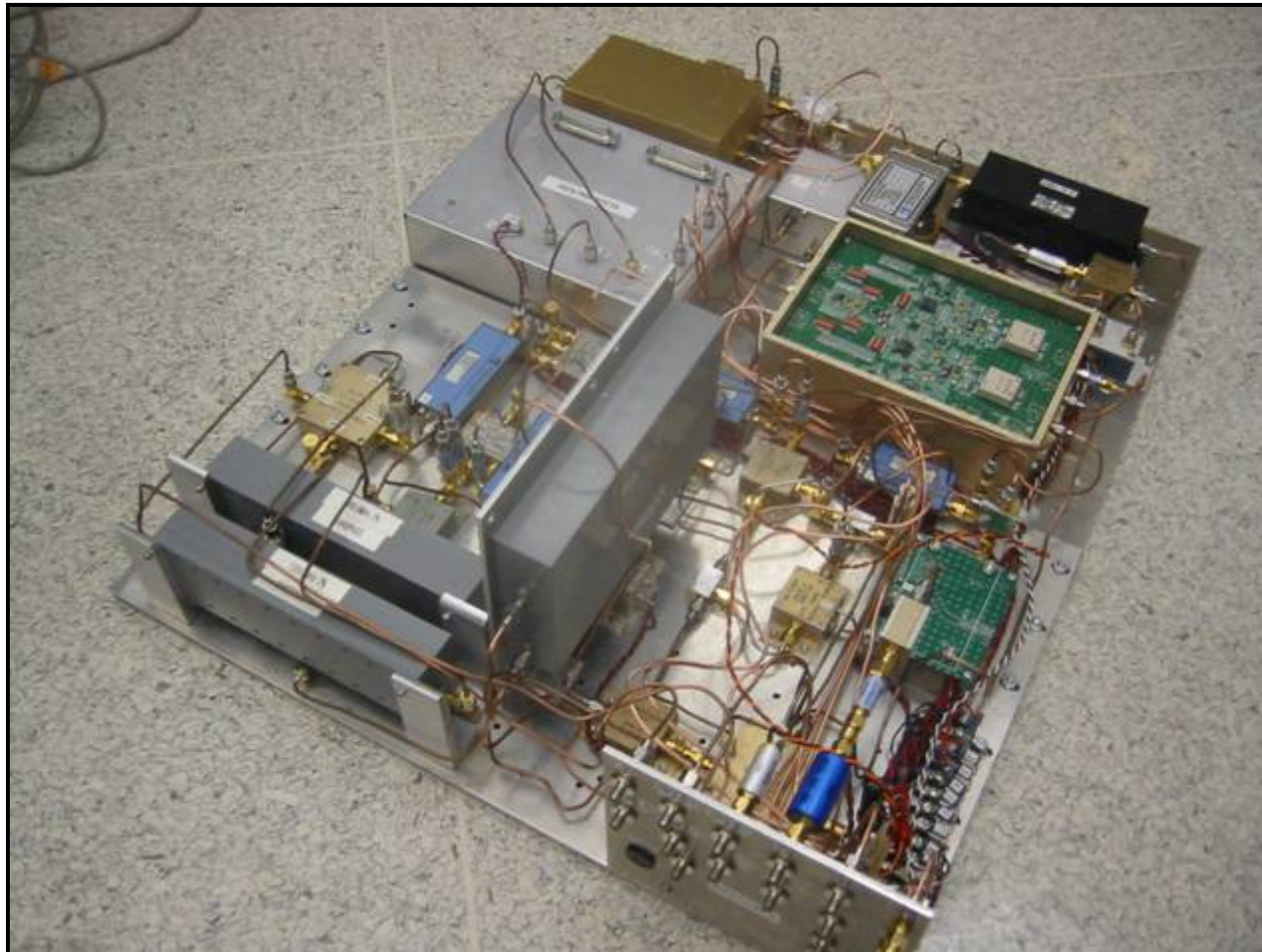



MEASURED SATELLITE RADIAL MOTION

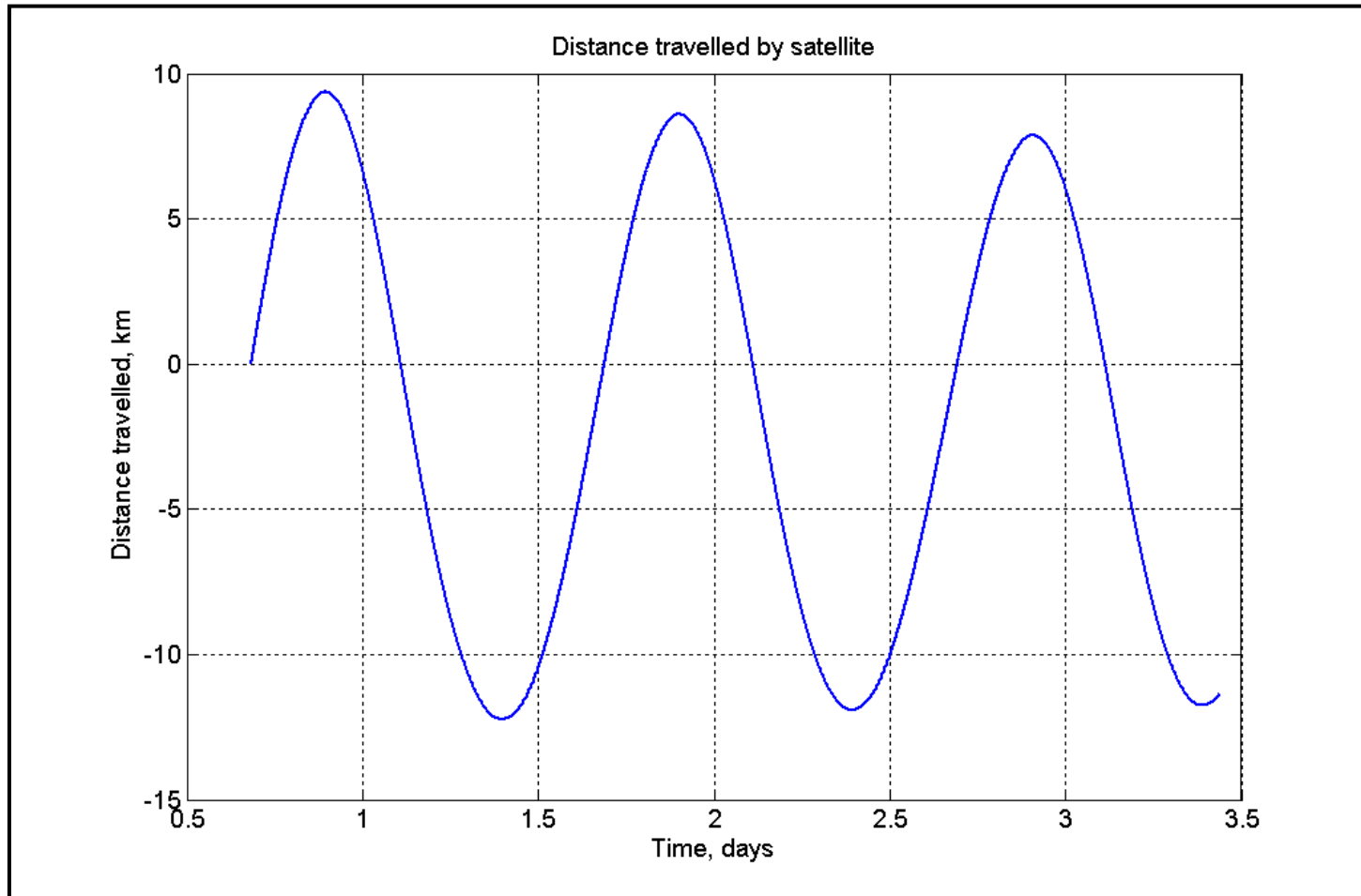

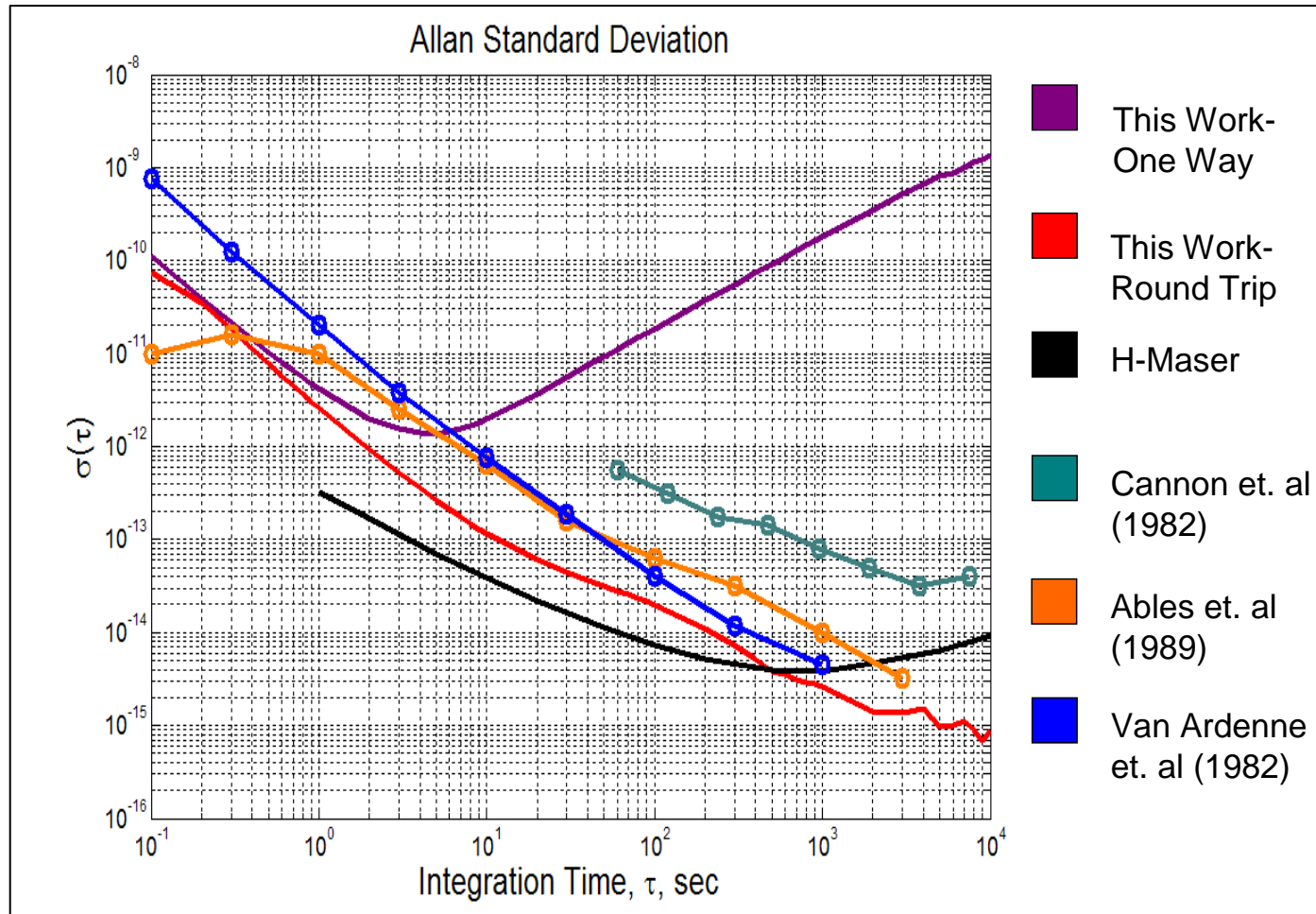

RMS TIME ERROR

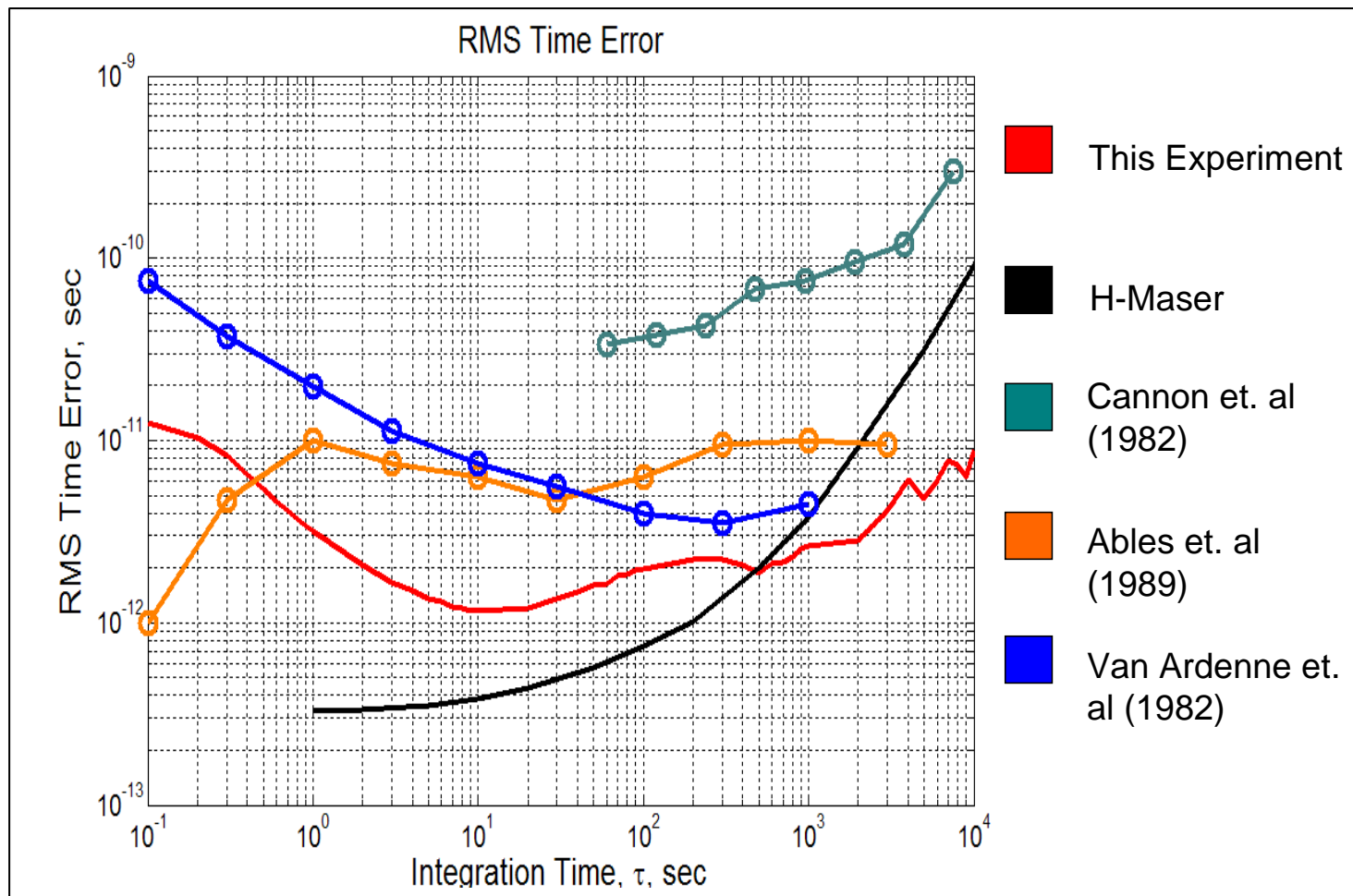



RESULTS



Achieved RMS time error

Authors	$\tau=1$ sec	$\tau=10$ sec	$\tau=100$ sec	$\tau=1000$ sec
This Work	3ps	1.2ps	2ps	2.6ps
Cannon et al	x	X	35ps	75ps
Ardenne et al	20ps	7ps	4ps	8ps
Ables et al	10ps	6ps	6ps	10ps



CONCLUSIONS



-
- TWTT may provide a cost effective alternative to Hydrogen Masers for use in VLBI
 - In this experiment, we were able to achieve better than 3ps time error for integration times ranging from 1 to 2000 seconds
 - The limiting factor seems to be earth station thermal stability

POSSIBLE FUTURE WORK

- Temperature stabilization
- Distributed experiment with interferometry



Acknowledgements



- This work was performed at the Jet Propulsion Laboratory, California Institute of Technology, under a contract with the National Aeronautics and Space Administration.

REFERENCES

- [1] J. Bardin, "Local Oscillator Distribution Using a Commercial Geostationary Satellite," M.S. Thesis, Electrical Engineering Department, University of California, Los Angeles, in preparation.
- [2] J. Bardin, S. Weinreb, D. Bagri, "Local Oscillator Distribution Using a Geostationary Satellite," *Experimental Astronomy*, accepted for publication.
- [3] Cannon, et. al, "Phase Stable Long Baseline Interferometry via A Satellite Link," Very Long Baseline Interferometry Techniques, 1982, Cepadues Press, Toulouse (443-458).
- [4] Van Ardenne, et al, "VLBI Clock Phase Comparison Using a Geostationary Satellite," Very Long Baseline Interferometry Techniques, 1982, Cepadues Press, Toulouse (459-466).
- [5] S. T. Ables, "A Report on the Phase Stability of the Aussat Phase Transfer System (draft)," July 1989
- [6] F. Gardner, *Phaselock Techniques*, John Wiley and Sons, New York, 1979.
- [7] A. Van Ardenne et al, "A High-Precision Phase-Comparison Experiment Using a Geostationary Satellite," *IEEE Transactions On Instrumentation and Measurement*, Vol IM-32, NO. 2, June 1983, 370-376.