

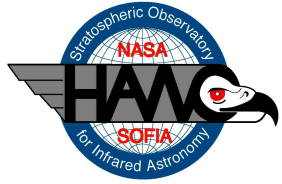

HAWC and SHARCII Detectors

Minoru M. Freund
NASA/GSFC

Harvey Moseley, Al Harper, Darren Dowell,
Dan McCammon, Christine Allen, Johannes Staguhn



Overview

- Detector Requirements
- Detector Characteristics
- Open Issues
- **Detector Screening and Testing**
- SHARC 1.5 Engineering run



Detector Requirements



Detector Requirements

- Bolometric 12x32 pixel array of ion-implanted Si PUDs
- Four bands between 40-300 μm
- Varying sky-loads between 20 - 60 pW/pixel
- Diffraction limited resolution
- Close-packed, 2D arrays >95% area filling factor
 - – 1.000 pitch \pm 0.004 mm, x-direction
 - – 1.000 pitch \pm 0.025 mm, y-direction, < 0.010 mm (goal)
 - – Detector row spacing: 1.000 \pm 0.025 mm.
 - – Detector alignment planarity better than 0.25 mm across pixel
- Background limited sensitivity
 - – $\text{NEP}(\text{total}) \approx 1.01\text{-}1.02 \cdot \text{NEP}(\text{Background})$
- Identical leg geometry for both HAWC and SHARCII



Summary of HAWC Detector Requirements

HAWC Design Parameters	Band 1	Band 2	Band 3	Band 4	Units
Central Wavelength	58	90	155	215	μm
Bandwidth	0.23	0.1	0.2	0.23	$\Delta\lambda/\lambda$
Pixel Size	2.25	3.50	6.00	8.00	arcsec
Image Diameter (FWHM)	6	9	16	22	arcsec
Detector array field size	27x72	42x112	72x192	108x256	arcsec
Detector array areal filling factor	>95	>95	>95	>95	%
Mean transmission (cold optics)	14	18	22	22	%
Mean transmission (warm optics plus vacuum window)	51	63	69	70	%
Mean transmission (atmosphere, 10 μm of H_2O , 40° elevation)	67	73	63	82	%
Background power per pixel	61	23	39	22	pW
NEP (thermal background limit, one pixel)	0.66	0.34	0.35	0.23	fW/Hz ^{1/2}
Frequency range (for background-limited performance)	5-100	5-100	5-100	5-100	Hz
NEFD (1 σ , background limit, $A\Omega=\lambda^2$)	1.3	1.3	1.0	0.7	Jy/Hz ^{1/2}
NEFD (1 σ , background limit, $A\Omega=\lambda^2$)	15.0	15.0	12.0	7.8	mJy(1 hr)

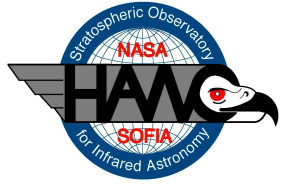

Detector Characteristics



Detector Model (1)

- HAWC detectors are described by a few primary parameters: R_0 , T_0 , G_0 , β

$$R(T) = R_0 e^{\sqrt{T_0/T}}$$

$$G(T) = G_0 T^\beta$$

$$\tau = c_v / G$$

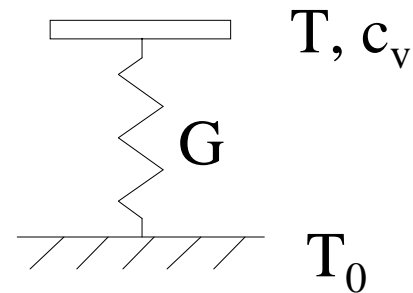

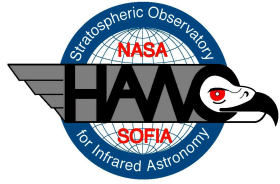

Detector Model (2)

- All I/V curves (measured at Caltech and Univ. of Wisconsin) from 0.2-4.2K (for given doping) are fitted by a 4-parameter nonequilibrium model (Mather, J. C. 1982, Applied Optics 21, 1125)
- This model predicts **most** detector parameters, including responsivity and NEP, but not time constant.
- Measurements show that the bolometers can be completely described by this model

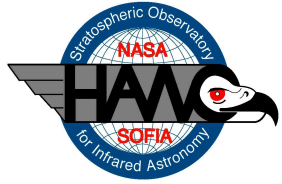

Detector Readout Diagram

- Detectors (200mK) are in a voltage divider circuit, with the warm (120K) JFETs located very close to detectors.
- Detectors: $R_D \approx 440M\Omega$ with no load.
- Load Resistors: $R_L \approx 400M\Omega$

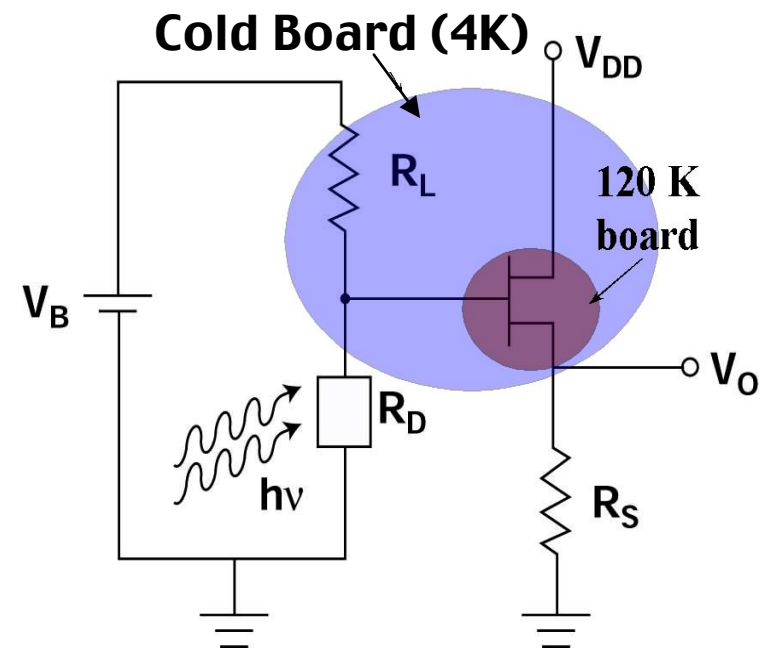



First thermistor implant results

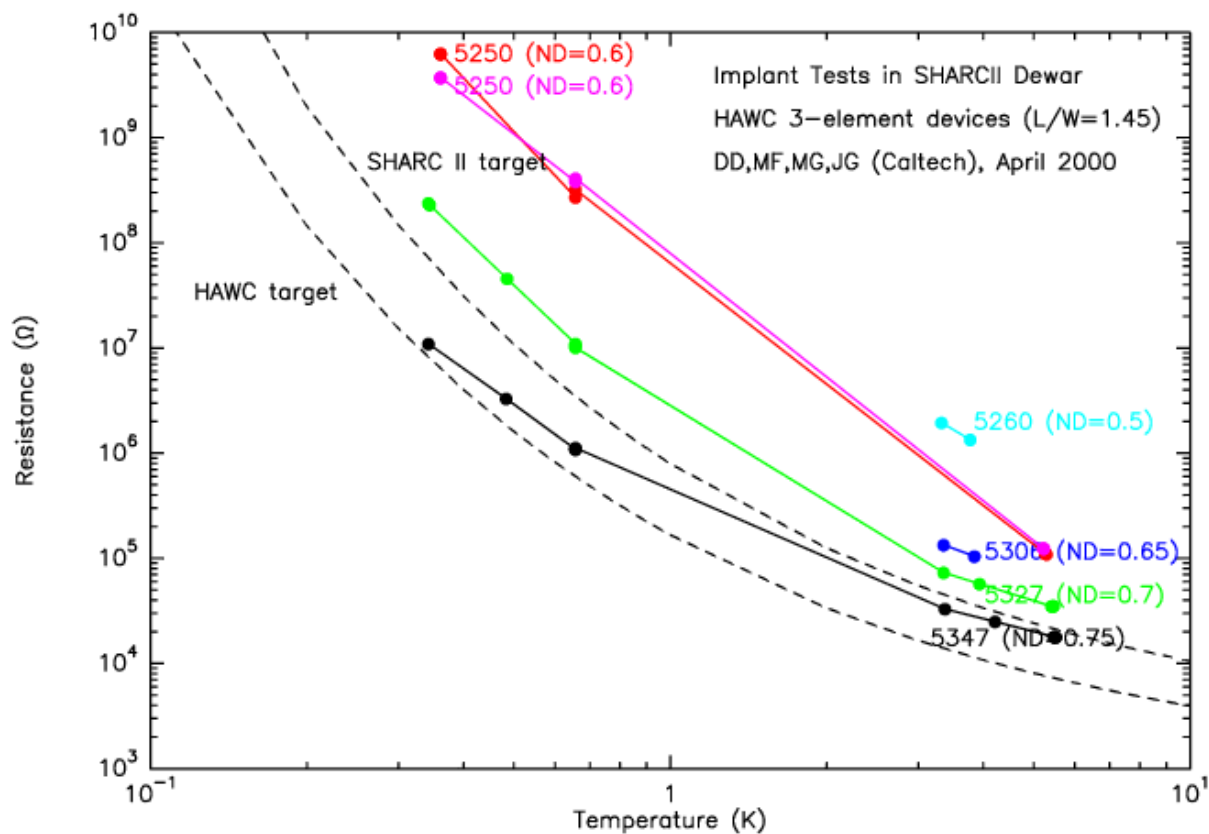

Result: HAWC: ND=0.75, SHARCII: ND≈0.73



I/V curves for 32-element G_0 packs

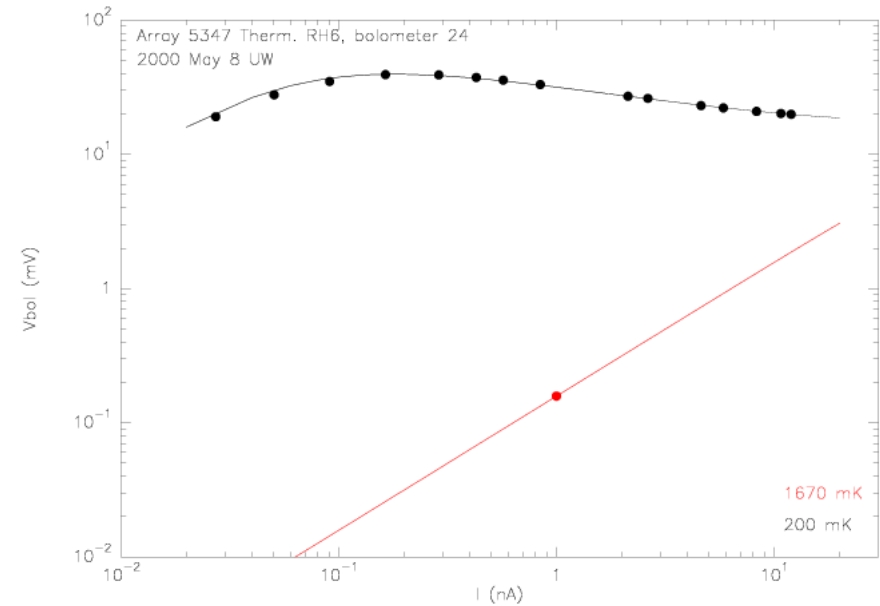
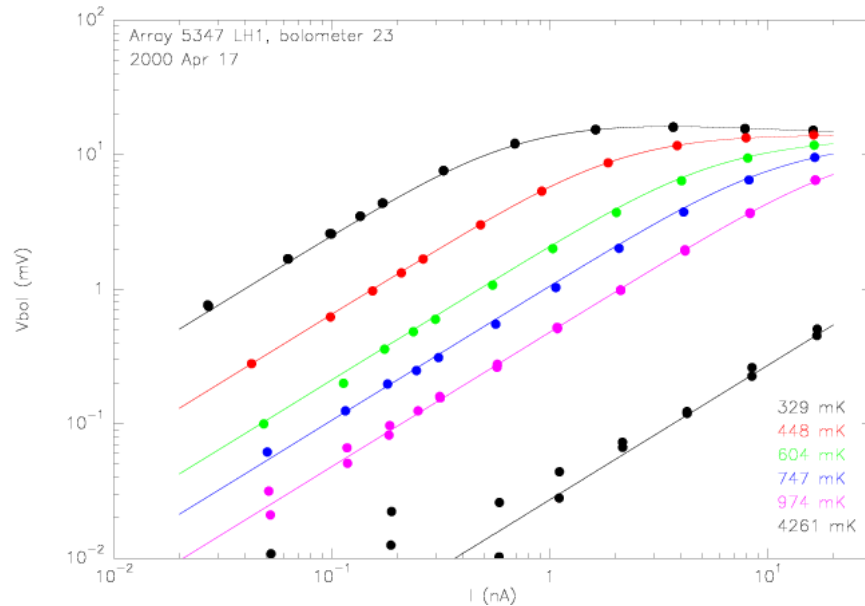

I/V curves for 2B leg geometry and $ND=0.75$

Left: Caltech 0.329-4.26K, Right: Wisconsin 0.20, 1.67K

Solid lines: Simultaneous 4-parameter fit to **ALL** data.

EXCELLENT AGREEMENT!



Noise Measurements

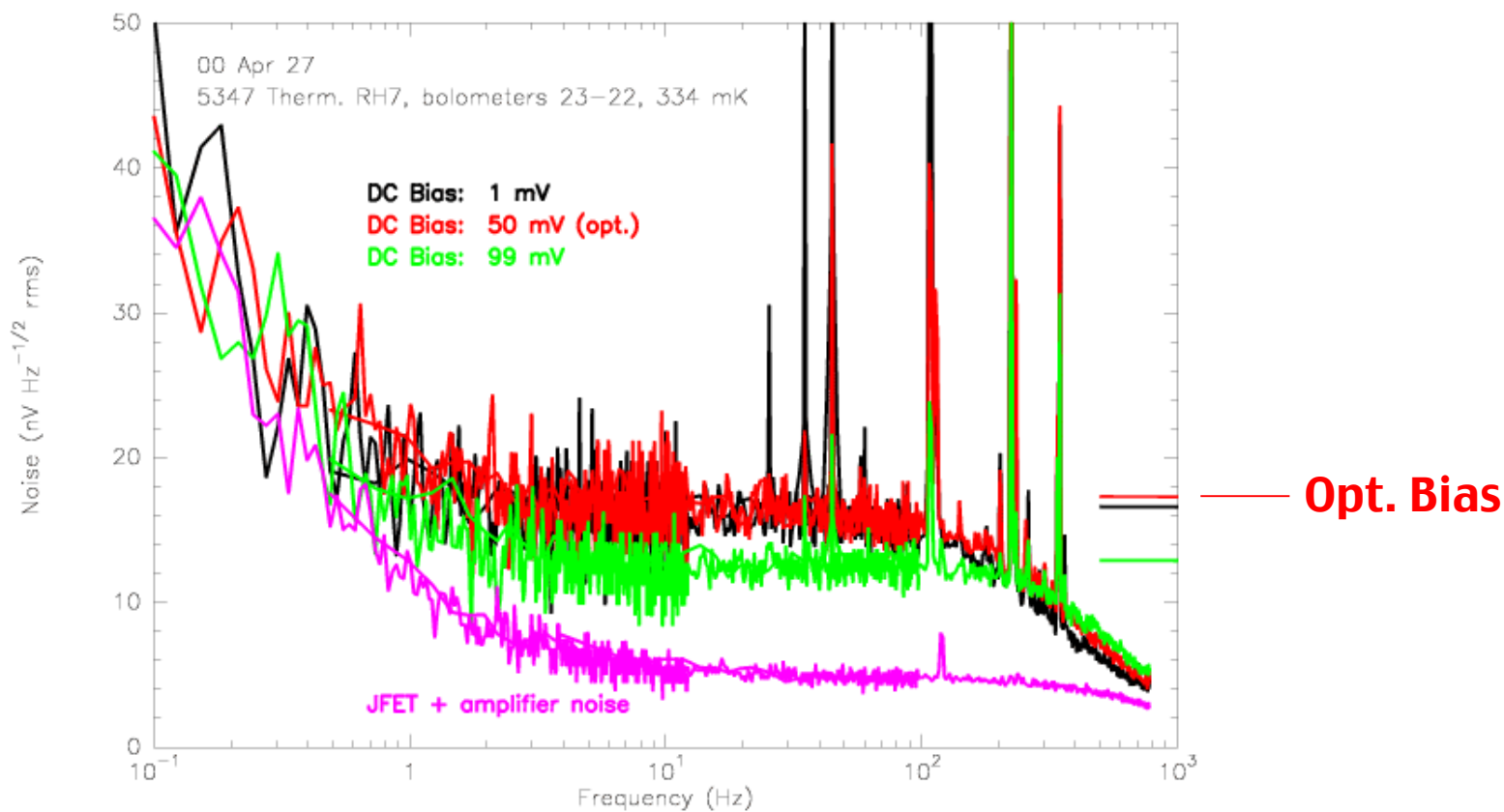

HAWC bolometer noise agrees with prediction (red bars)



Detector Recipe Summary

Notes		HAWC	SHARC II
(1)	Leg Geometry	2B	2B
(2)	Back-side leg requirements	Same as front-side legs, but with no electrical connection to the resistor, to reduce vibrational-coupling between rows of detectors	Same as front-side legs, but with no electrical connection to the resistor, to reduce vibrational-coupling between rows of detectors
(3)	Resistor length to width Resistor size	1:1 As close to full area as possible: ($\approx 940\mu\text{m}$) ²	1:1 As close to full area as possible: ($\approx 940\mu\text{m}$) ²
(4)	Target Resistance Acceptable Target Resistance Range	13.5M Ω @ 0.35K 8-25M Ω @ 0.35K	10M Ω @ 0.5K 5-20M Ω @ 0.5K
(5)	Absorber film resistance Absorber Material	160 Ω /sq Bi with SiO overcoat Non-shorting Absorber	400 Ω /sq Bi with SiO overcoat Non-shorting Absorber
(5a)	Time constant	Required 10ms Goal: 3ms	Required 10ms Goal: 3ms
(6)	On-chip Thermometer Thermometer wiring	Frame device Dimensions and resistance same as (3), (4) Four-wire	Frame device Dimensions and resistance same as (3), (4) Four-wire
(7)	Bond pads	Large enough for repeated bonding	Large enough for repeated bonding

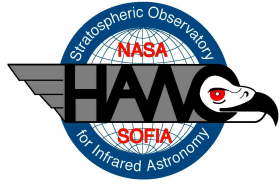

Note (1)

Cell Name	Torsion Bar Width	Torsion Bar Length	Radius of Curvature	Strap Width	Strap Length	Metal on Torsion Bar	Added Metal on Strap	Implant Size LxW
2B	16 μ m	421 μ m	70 μ m	295 μ m	500 μ m	n/a	16 μ m wide leads (4 ea.)	940x940 μ m ²

- The 2B design (C. Allen nomenclature) gives a $G(T) = G_0 \cdot T^\beta$ [nW/K] for both HAWC and SHARC-II
 - $G_0 = 1.5 \text{ nWK}^{-2.35}$
 - $\beta = 1.35$

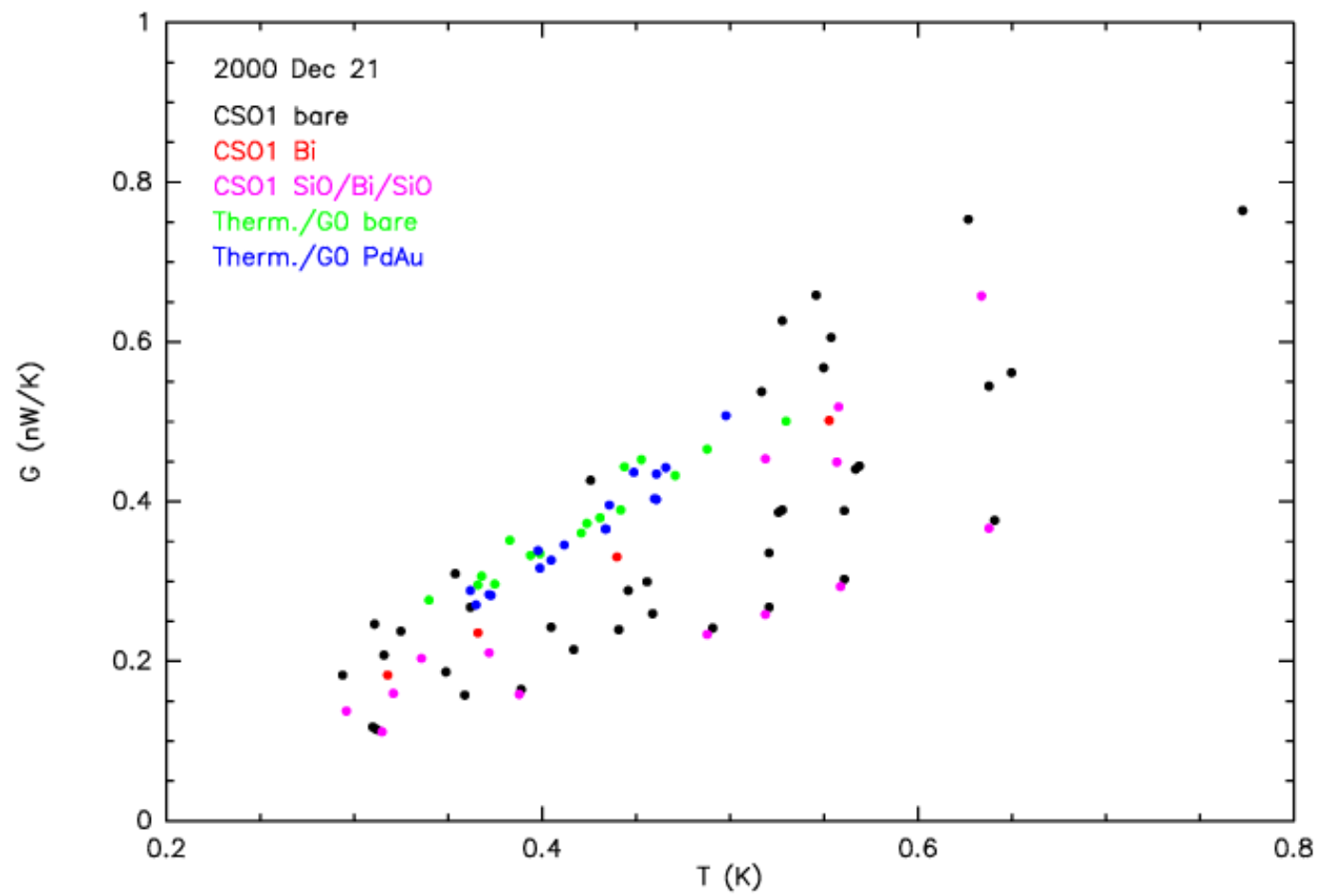

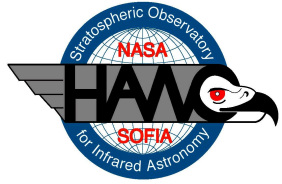

Note (4)

- Target Resistance: $R(T_{\text{operate}})$
 - $R_0 = 1300\Omega$
 - $T_0 = 30\text{K}$ (HAWC)
 - $T_0 = 40\text{K}$ (SHARC-II)

$$R(T) = R_0 e^{\sqrt{\frac{T_0}{T}}}$$



Summary of HAWC/SHARCII



	HAWC (BGP = 20pW)	HAWC (BGP = 60pW)	SHARC II	units	Remarks
T_{bath}	0.200	0.200	0.320	K	
T_0	30	30	40	K	
R_0	1300	1300	1300	Ω	
Volume _{thermistor}	$2.7 \cdot 10^{-7}$	$2.7 \cdot 10^{-7}$	$2.7 \cdot 10^{-7}$	cm^3	
G_0	1.5	1.5	1.5	$\text{W K}^{-2.35}$	
β ($G = G_0 T^\beta$)	1.35	1.35	1.4		
R (load resistor)	400	400	200	$\text{M}\Omega$	
T (load resistor)	4.2	4.2	2.0	K	
Background Power	20	60	75	pW	
$\text{NEP}_{\text{background}}$	$2.2 \cdot 10^{-16}$	$6.6 \cdot 10^{-16}$	$4.4 \cdot 10^{-16}$	$\text{W s}^{1/2}$	
voltage noise (amp.)	$6 \cdot 10^{-9}$	$6 \cdot 10^{-9}$	$5 \cdot 10^{-9}$	$\text{V s}^{1/2}$	
V_{bias}	300	1050	550	mV	
$V_{\text{bolometer}}$	12.3	8.5	16	mV	
I	0.9	2.5	2.7	nA	
$R_{\text{bolometer}}$	13	3.5	5.9	$\text{M}\Omega$	
$Z_{\text{bolometer}}$	4.5	1.5	2.1	$\text{M}\Omega$	
$T_{\text{bolometer}}$	0.34	0.48	0.56	K	
G	0.28	0.46	0.67	nW/K	
S	$3.7 \cdot 10^8$	$1.1 \cdot 10^8$	$1.2 \cdot 10^8$	V/W	
τ (elec.)	3-10	3-10	3-10	msec	With absorber

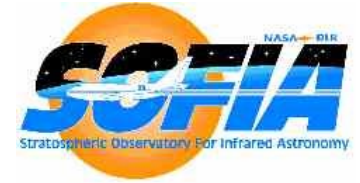
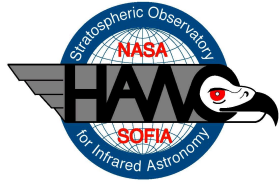

HAWC detectors

HAWC Design Parameters	Band 1	Band 2	Band 3	Band 4	Units
Central Wavelength	58	90	155	215	μm
Bandwidth	0.23	0.1	0.2	0.23	$\Delta\lambda/\lambda$
Pixel Size	2.25	3.50	6.00	8.00	arcsec
Image Diameter (FWHM)	6	9	16	22	arcsec
Detector array field size	27x72	42x112	72x192	108x256	arcsec
Detector array areal filling factor	>95	>95	>95	>95	%
Mean transmission (cold optics)	14	18	22	22	%
Mean transmission (warm optics plus vacuum window)	51	63	69	70	%
Mean transmission (atmosphere, 10 μm of H_2O , 40° elevation)	67	73	63	82	%
Background power per pixel	61	23	39	22	pW
NEP (thermal background limit, one pixel)	0.66	0.34	0.35	0.23	$\text{fW}/\text{Hz}^{1/2}$
Frequency range (for background-limited performance)	5-100	5-100	5-100	5-100	Hz
NEFD (1σ , background limit, $A\Omega=\lambda^2$)	1.3	1.3	1.0	0.7	$\text{Jy}/\text{Hz}^{1/2}$
NEFD (1σ , background limit, $A\Omega=\lambda^2$)	15.0	15.0	12.0	7.8	$\text{mJy}(1 \text{ hr})$
Measured Performance of HAWC detector					
2B ($\rho=0.75$, no metal)					
$R_0 = 1300$, $T_0 = 30$					
$G_0 = 1.21\text{e-}9$, $\beta=1.37$, Readout 10Hz					
NEP(detector)	0.110	0.050	0.069	0.049	$\text{fW}/\text{Hz}^{1/2}$
Detector Temperature	500.0	363.0	422.0	360.0	mK



Detector Current Status

- HAWC/SHARCII detectors share common leg geometry \Rightarrow leads to lower costs.
- Detector noise in 5 - 30 Hz range is consistent with theory.
- Detectors are expected to be background limited:
 $NEP(\text{Total}) = 1.01 - 1.02 \times NEP(\text{background})$
- Three open issues
 - Excess Heat capacity
 - Absorber performance
 - Resistance gradient

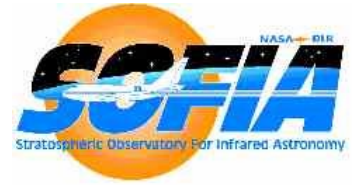
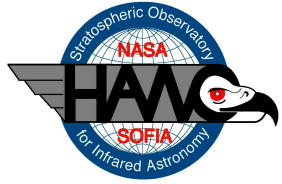

Open Issues



Open Issue: Absorber Material

- We have selected a candidate recipe using a Bi film with 1000Å SiO overcoat (for passivation)
- We will characterize the absorption of the Bi/SiO films
- We have an established recipe, but need to complete heat capacity and optical absorption .



Absorber Material Testing

- Test Bi films of different thicknesses with SiO overcoats for HAWC and SHARC
- Establish recipe and process for absorbing layer deposition
 - DC resistance characterizes impedance in far IR
 - Resistance varies with temperature in a manner which is process dependent
 - Heat capacity must be consistent with τ reqt.

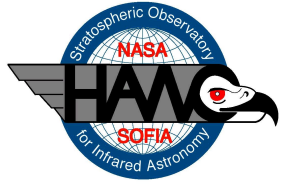

Open Issue: Excess c_v

- Detectors produced have larger than expected heat capacity (ranging from 2 - 5 times)
- Contamination is suspected, but anomalous heat capacity in SOI cannot be ruled out
- Present heat capacities are acceptable for SHARC II, marginal for HAWC
- Questions:
 - What diagnostic tests do we do?
 - When do we stop?

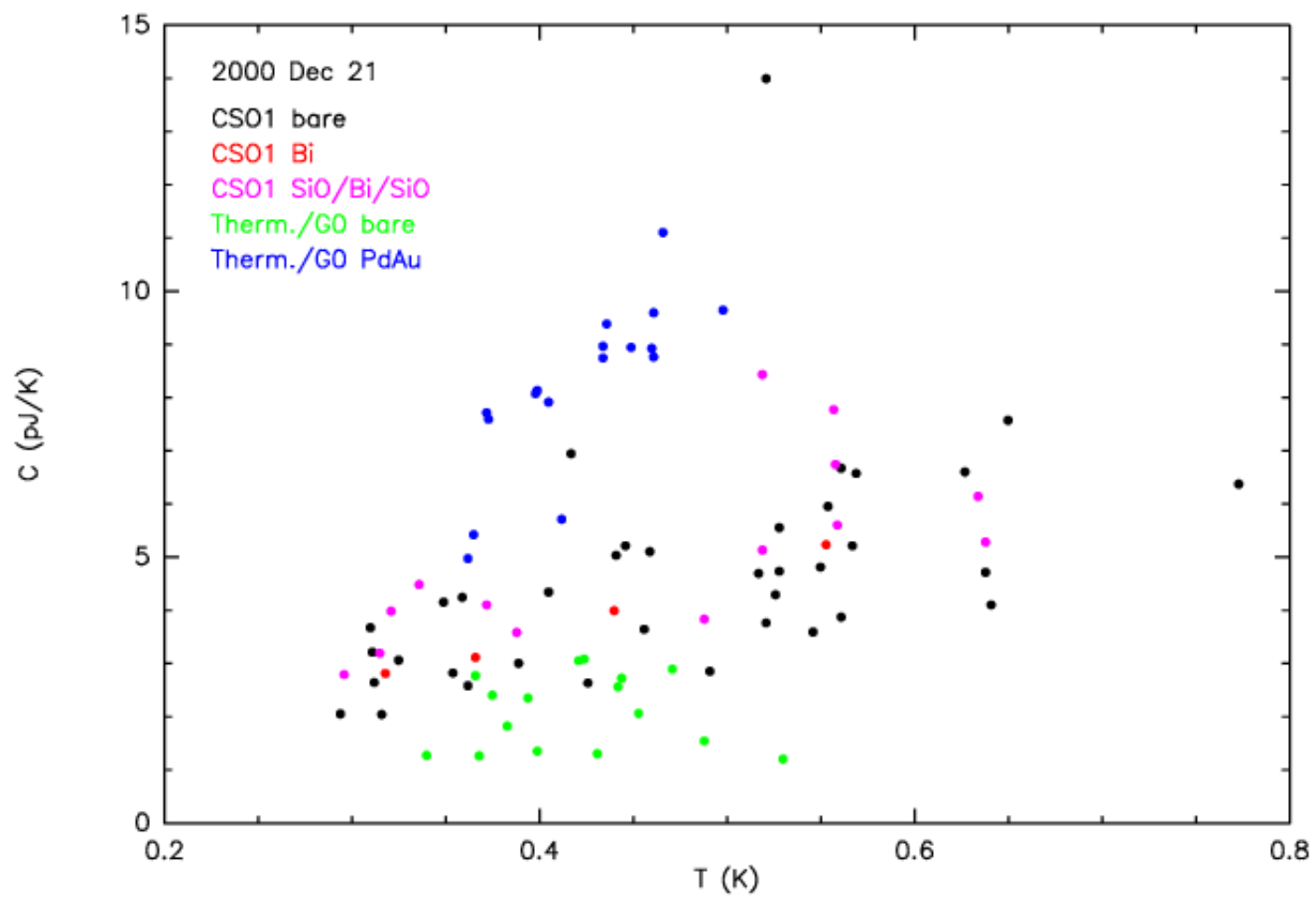



Predicted Heat Capacity

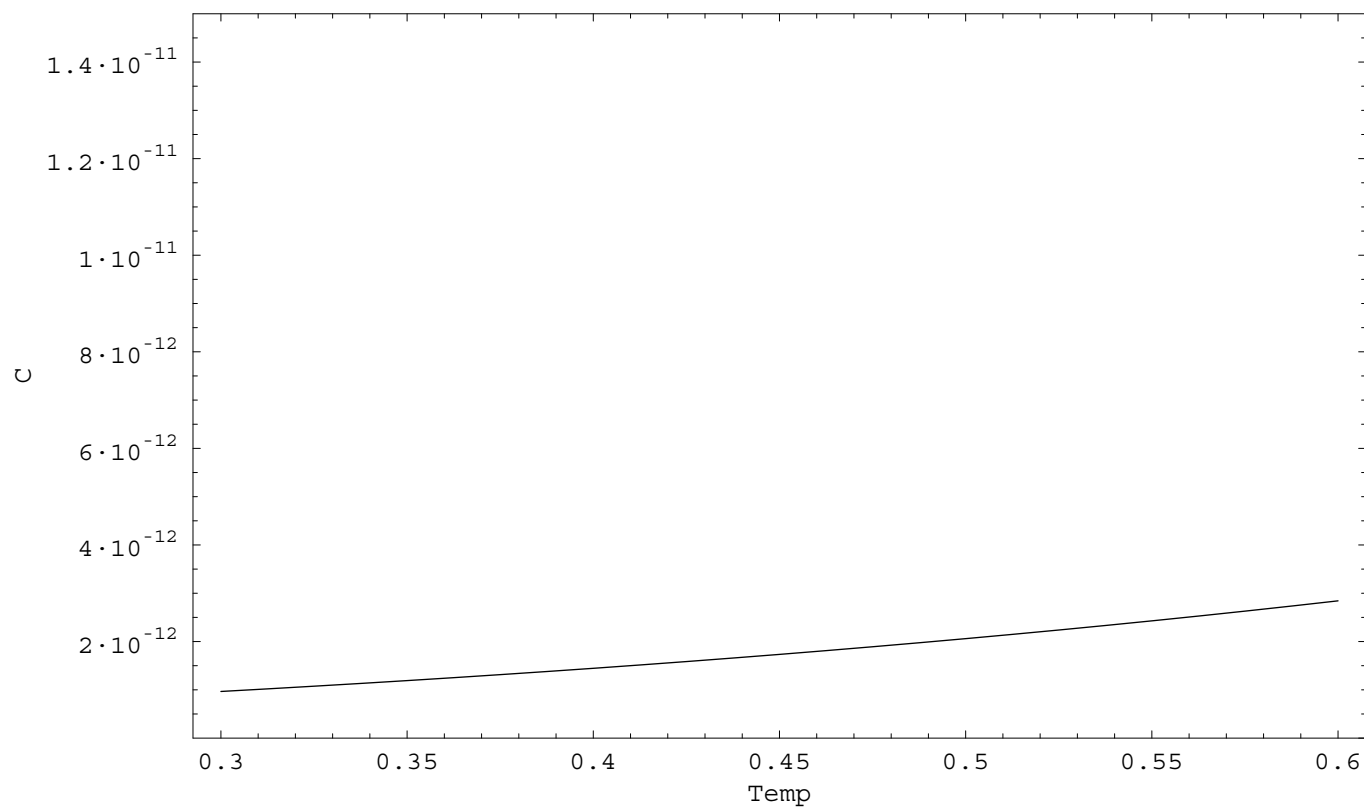

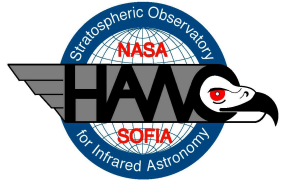

Open Issue: Resistance Gradients



- At least one wafer shows resistance variations of a factor of 5 across a single array
- We will carefully screen wafers with 3-element devices on the corner of wafers.
- We will screen 32-element arrays to eliminate those not meeting requirements
 - We do not know the expected yield of acceptable devices

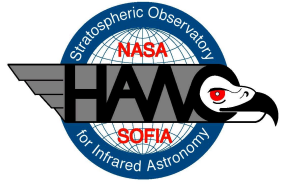

Addressing Identified Problems

- Technical approach will be defined by detector group.
- System performance implications will be evaluated, looser reqts. assessed on detector subsystem if possible.
- Clear decision point and process must be defined for key questions



Detector Screening & Testing: From Wafers to Focal Plane Arrays

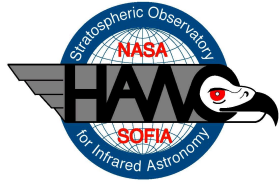

Principles

- **We scoped the detector fabrication and testing so that we have enough detectors**
- **This is a processing and handling issue, not a basic physics problem**

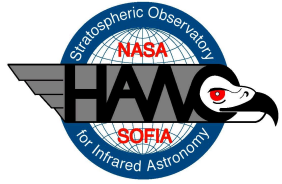

Process Overview

Procedure:

- Test: Screening wafers with correct doping
→ Darren Dowell
- Test: Visual inspection of 32-element devices
→ Christine Allen
- Fold PUDs → George Voellmer
- Test: cryogenic test of 32-element PUDs
→ Mino Freund
- Stack and integrate into SHARCII/HAWC assemblies →
George Voellmer
- Test: Flight Array in Flight System (after delivery of detectors)
→ Chicago

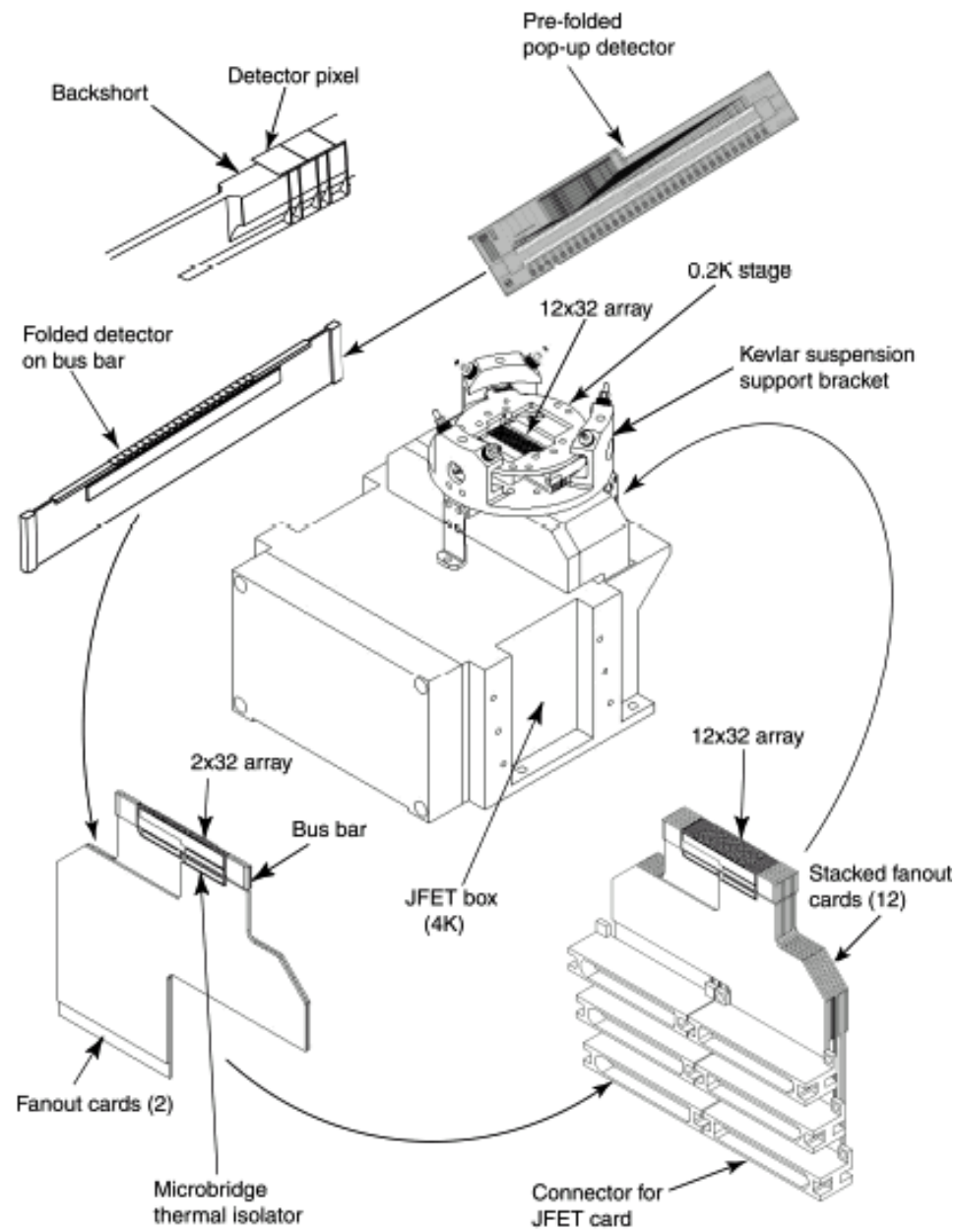



Screening process

Yield is not a hard requirement, but educated guess

$$\text{Yield} \approx (0.12-0.25) \cdot 0.9 \cdot 0.75 \cdot 0.75$$

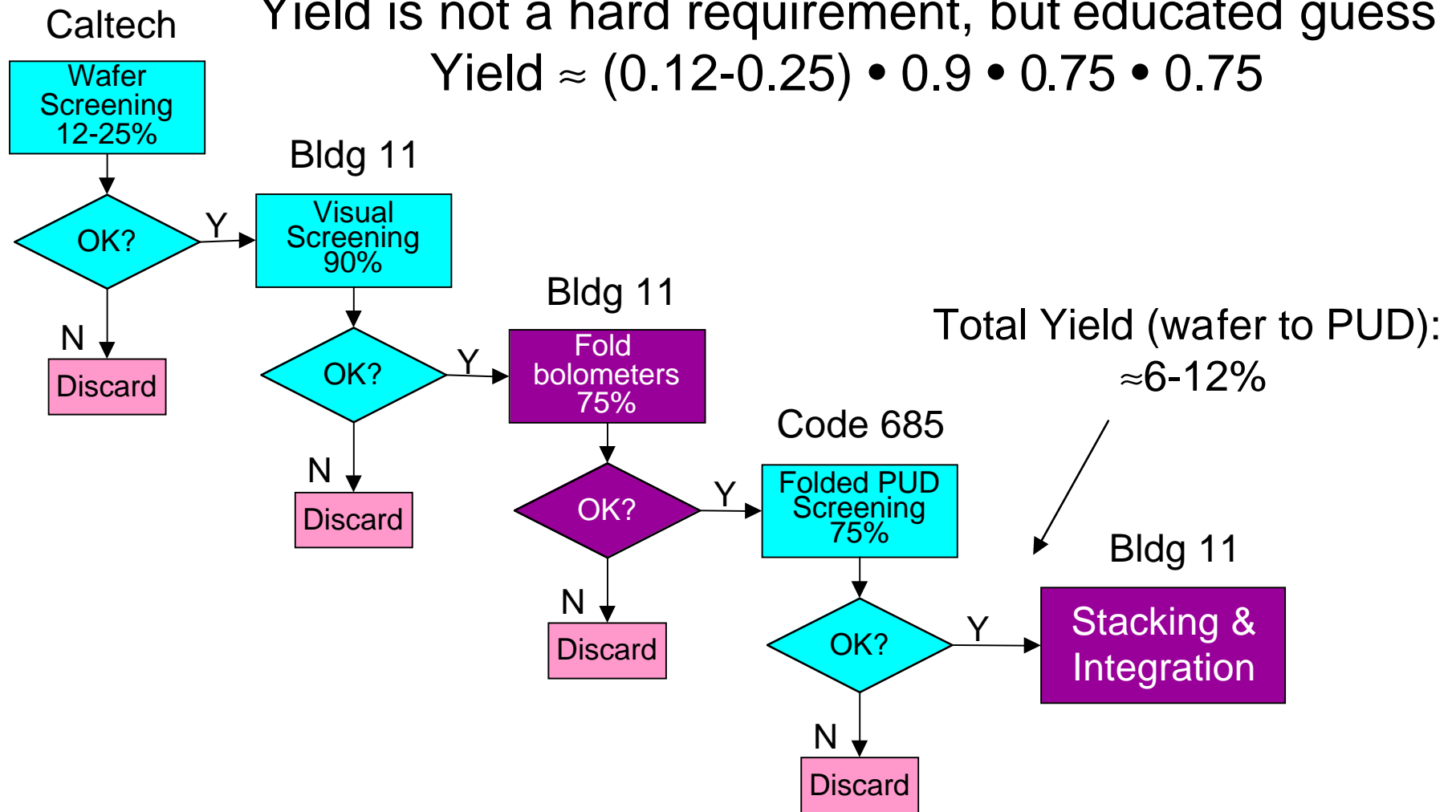

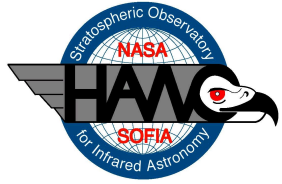

Wafer screening test plan

- Screening devices: additional 3-element devices on wafer which do not require sacrificing 32-element bolometer arrays.
- Same design as for HAWC/SHARC II detectors.
- Bolometer -- low thermal conductance; for thermal characterization



Wafer Screening (1) -- R(T) screening

- For each wafer, measure resistance of device T1.
- Fixed current excitation (~ 1 nA) applied via external warm load resistor.
- Current measured with Keithley 487 picoammeter.
- Voltage measured with HP 34401A multimeter.
- $T = 0.3$ K, 1.5 K, 4.2 K

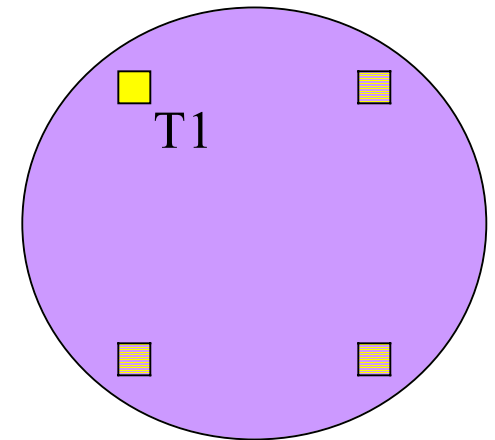

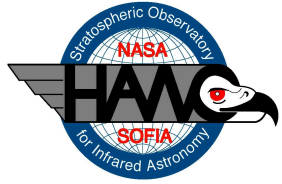

Wafer Screening (2) -- R(T) confirmation



- From first round of screening, identify candidate wafers with desired R(T).
- For each candidate wafer, measure resistance of device T4.
- T = 0.3 K, 1.5 K, 4.2 K
under load 0.3-0.55 K

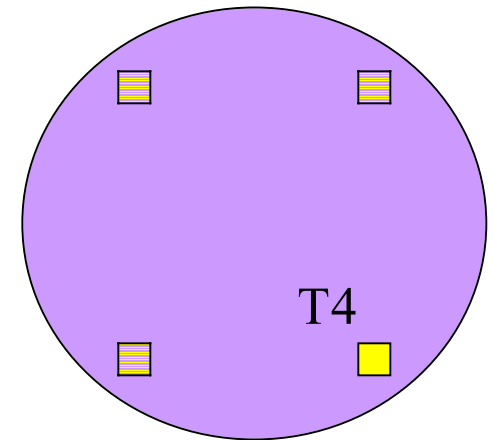



Wafer Screening (3) -- thermal characterization

- From wafers with correct $R(T)$, prepare devices T2 and T3 with candidate absorbing films.
- Use cold load resistors and JFETs to gather I/V curves.
- Compare thermal conductance with target.
- Measure heat capacity of absorbers.
- Verify low noise in signal band.
- $T = 0.3 \text{ K}$

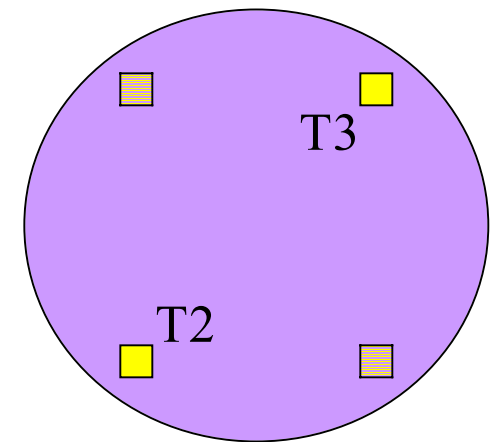



Folding PUDs

- **PUD folding can be controlled, and several consecutive successful folds have been made. Still, we expect some lower yield.**
- **Folding is different for SHARCII (precise back-short distance) and HAWC.**
- **Estimated time: 1 fold/day**

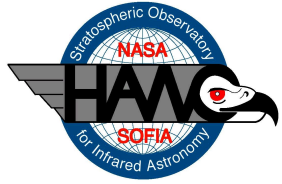

Folded PUD testing (1)

- **Total time for testing 2x32 PUDs at the same time: 1 week**
- **Total PUDs for SHARCII: 12**
 - **When we get 12 acceptable PUDS, or we run out of wafers, we stop building PUDs**
- **Total PUDs for HAWC: 12**
 - **We will continue building PUDs until we have a full complement of 12**
- **Total PUDs to test: Minimum 24, more likely 36, i.e. 12–18 weeks of testing.**



Folded PUD testing (2)

- **High Temperature ($\geq 1.5\text{K}$)**
 - **Room Temperature**
 - **Visual Inspection**
 - **Continuity: Check hardware test setup up to wire bonds**
 - **77K: Continuity test**
 - **4.2K, 1.5K**
 - **Continuity**
 - **I/V curves**

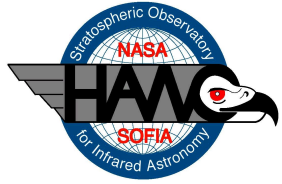

Folded PUD testing (3)

- **Low Temperature (0.22–0.6 K)**
 - **I/V & Load under Radiation**
⇒ **R(T), G(T)**
 - **Noise [range of biases]**
 - **Noise [range of optical loads]**
 - **Time constant τ from chopped external optical loads.**
- **We will measure all relevant detector parameters**

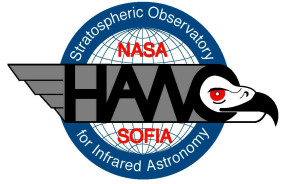

Testing Conclusions

- This is a processing and handling issue, not a basic physics problem.
- We understand most of the details of the detectors.
- We still have some minor detector issues.
- We scoped the detector fabrication and testing so that we have enough detectors.
- Buildup of test-station, testing plan, testing procedures in progress .
- We will have optical testing using a chopper.

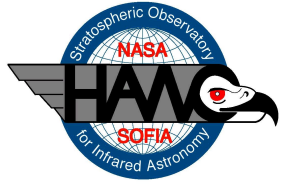

SHARC 1.5 Engineering Run at Caltech Submillimeter Observatory

2000 September 16-21

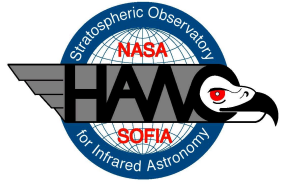

SHARC 1.5

Engineering bolometer array

- Prototype instrument for SHARC II
- Software and Mechanical Interface testbed
- Unfolded one-row PUD
- Thermistor ‘assortment pack’ made for HAWC/SHARCII bolometer selection, doping 5347, device RH7
- Pd/Au absorber, $\sim 175 \Omega/\text{square}$ with goal of 50% broadband absorption
- Black paint ~ 1 cm behind bolometers

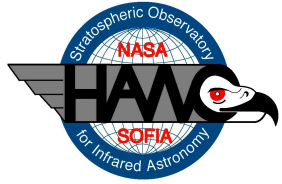

SHARC 1.5

Bolometer packaging in Lab

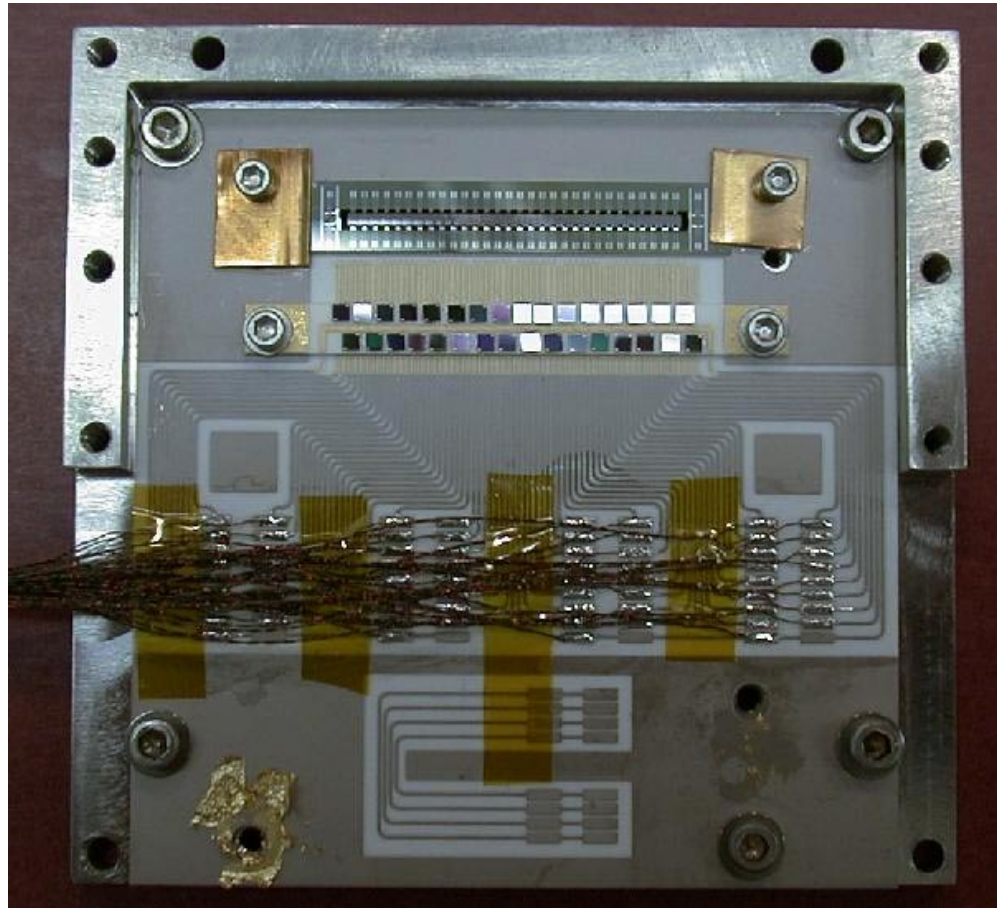

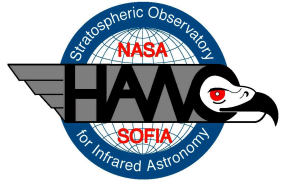

SHARC 1.5 First Light Image!

- Orion molecular cloud, the best-studied stellar nursery
- Image shows thermal emission at 350 μ m wavelength
- Observations made September 2000 by Caltech SHARCII team and GSFC members of the HAWC detector team.
- Prototype of semiconducting “pop-up detector” bolometer arrays.
- Single 1x16 array used; final array will be 12x32.

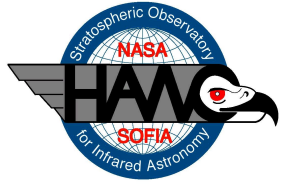

Actual SHARC1.5 (HAWC Prototype) Array Image

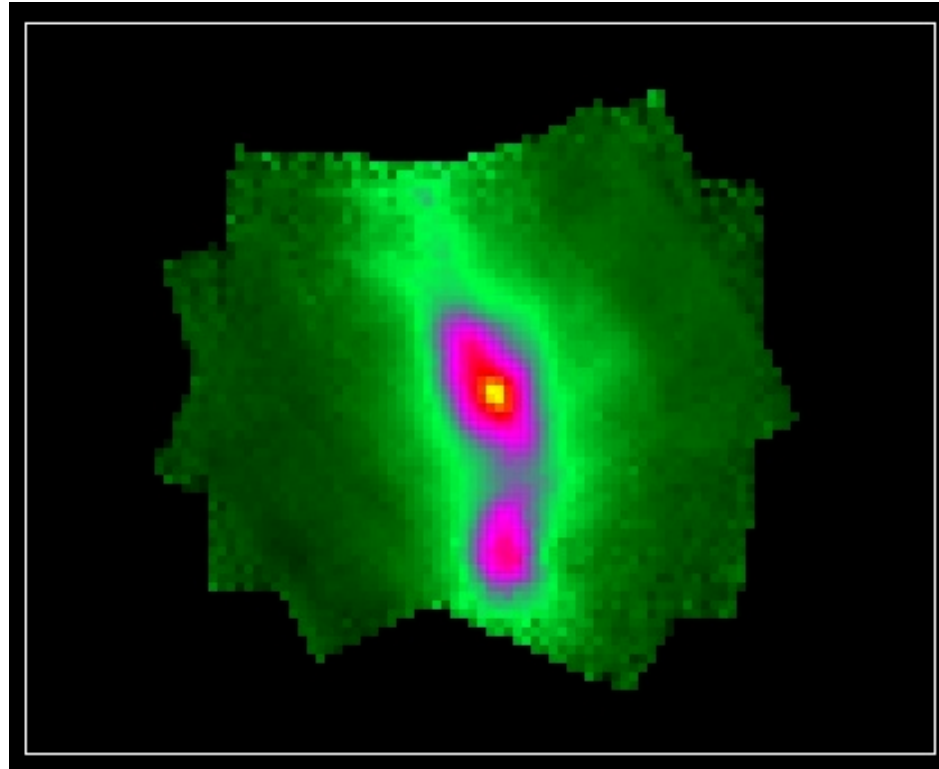

- **Orion Molecular Cloud, $\lambda = 350 \mu\text{m}$**



Actual HAWC Prototype Array Image of Uranus

